

## Project Overview

This project focuses on the design of a scaled modular pylon capable of supporting multiple payload configurations for the MQ-9 autonomous aircraft. The design must integrate mounting provisions for two Line Replaceable Units (LRUs) and support two payload carriage systems: an expanded Bomb Rack Unit (BRU) with both 14-inch and 30-inch lug spacing, and a Missile Rail Launcher (MRL) with 30-inch mounting points. The pylon structure is enclosed by a fairing that improves aerodynamic performance.

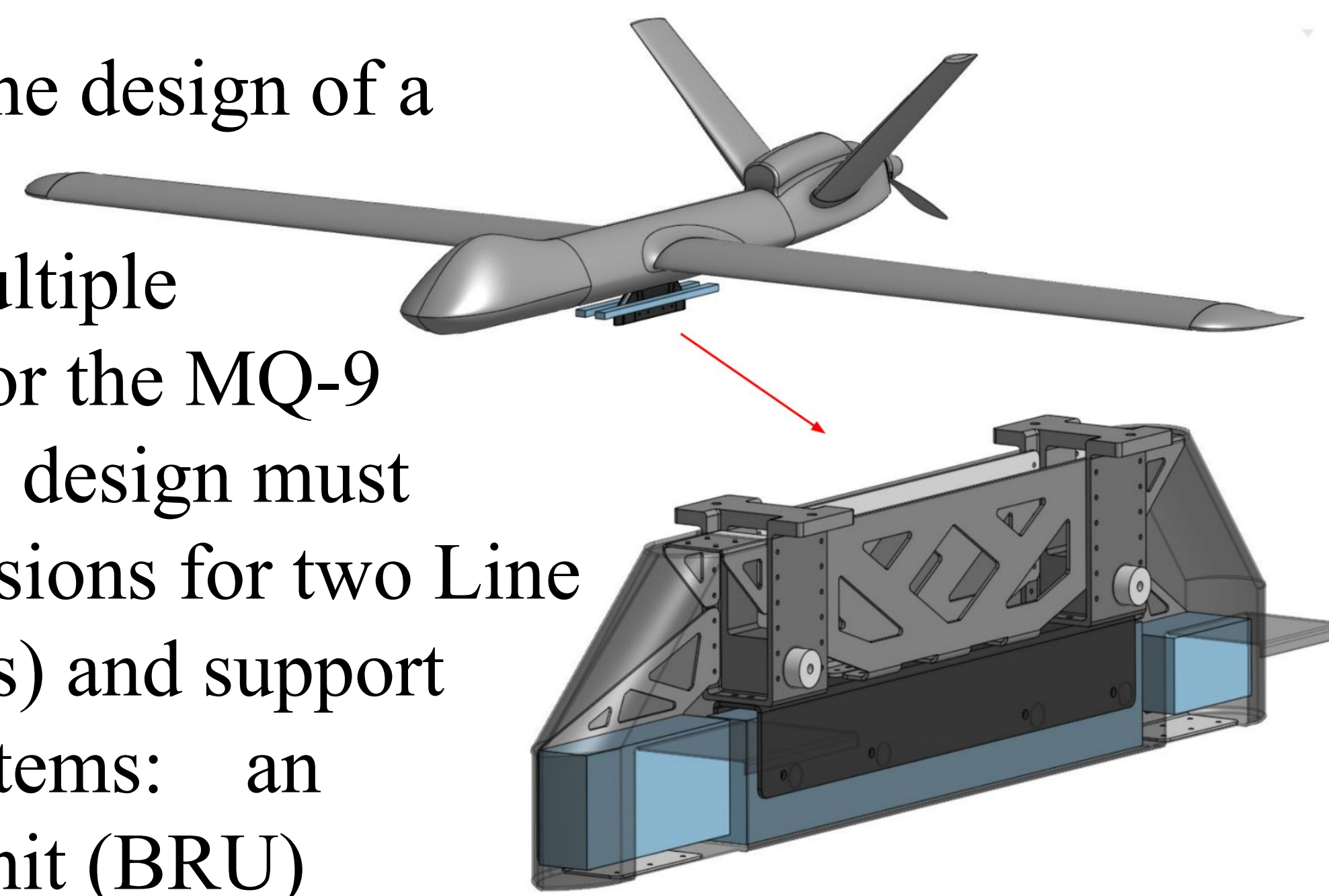

## CAD Assembly

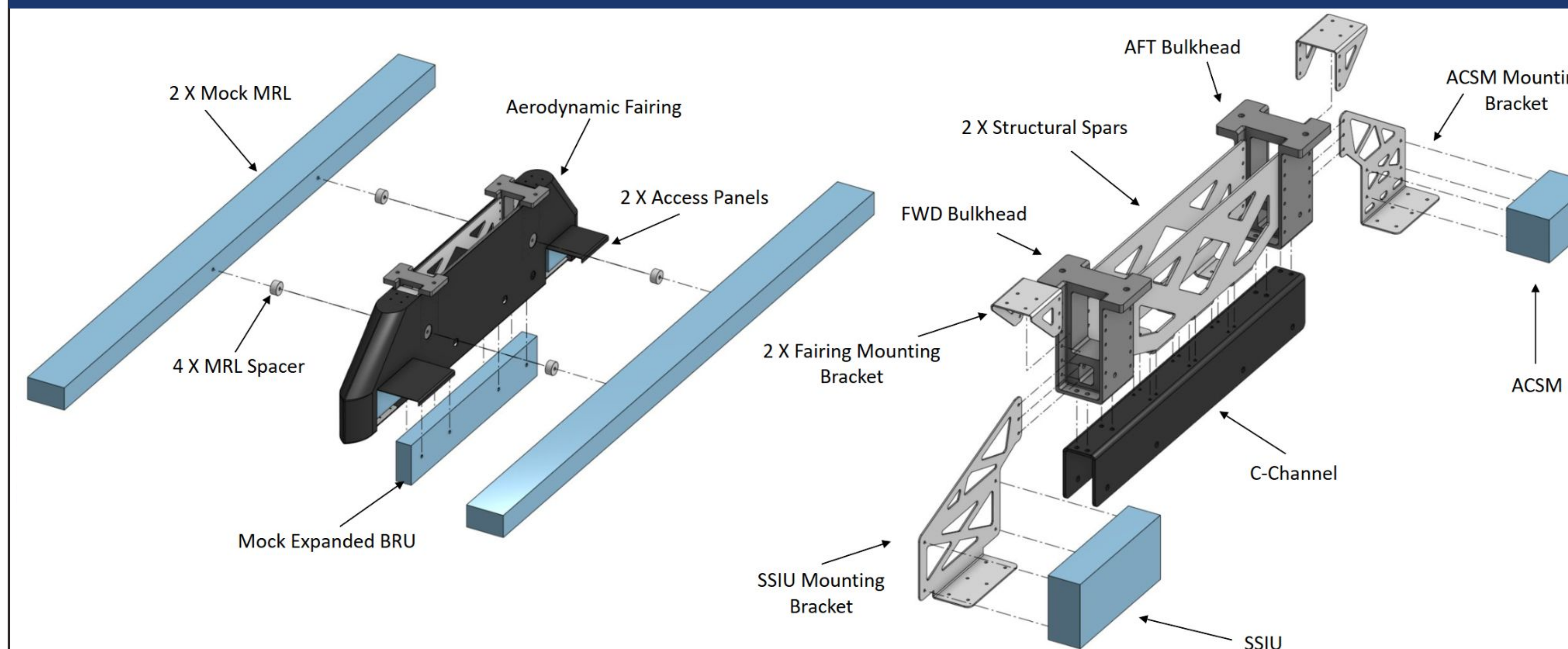

## Topology Optimization

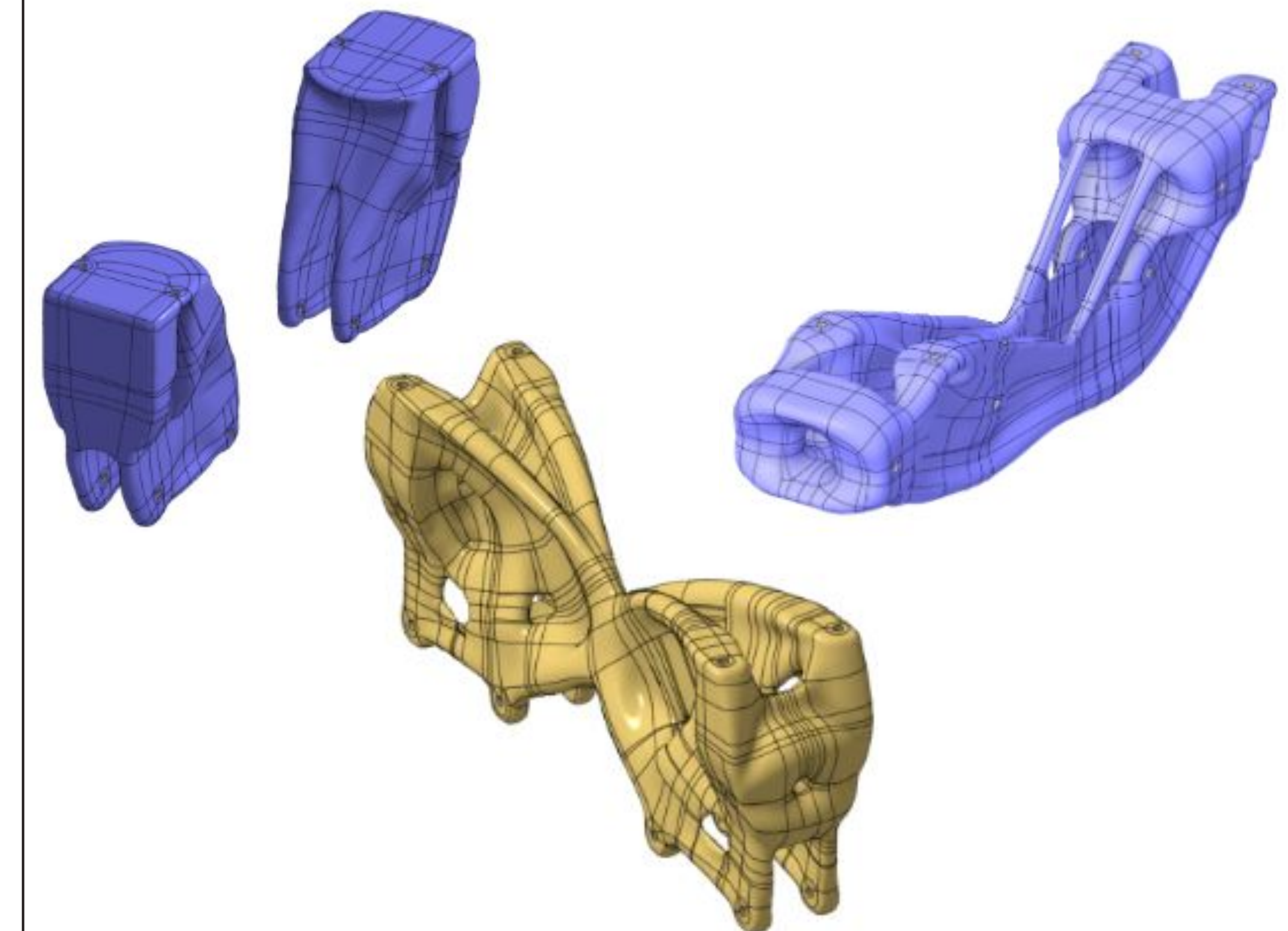

- Visualized load transfer through the pylon
- Aided early-stage design iterations & later design decisions

## Meet the Team



Emiliano Mondragon Flores (M.E.)  
Team Lead



Wynter Trumpfheller (M.E.)  
Manufacturing Lead



Nathan Weast (M.E.)  
Design Lead



Jake Finn (M.E.)  
Testing/Instrumentation Lead

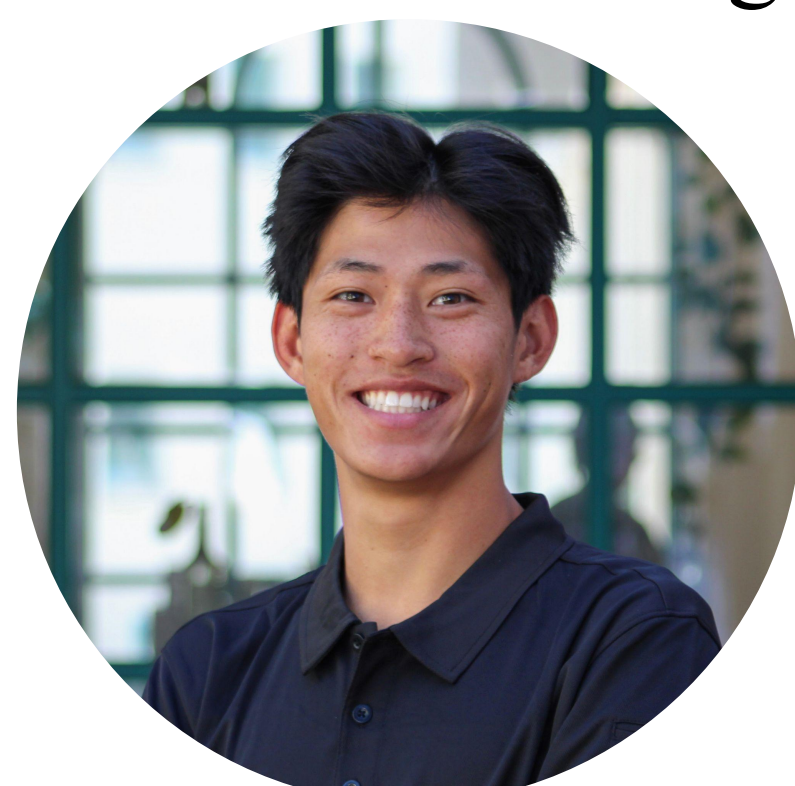

Justin Tong (M.E.)  
QC & Analysis Lead

## System Level Diagram

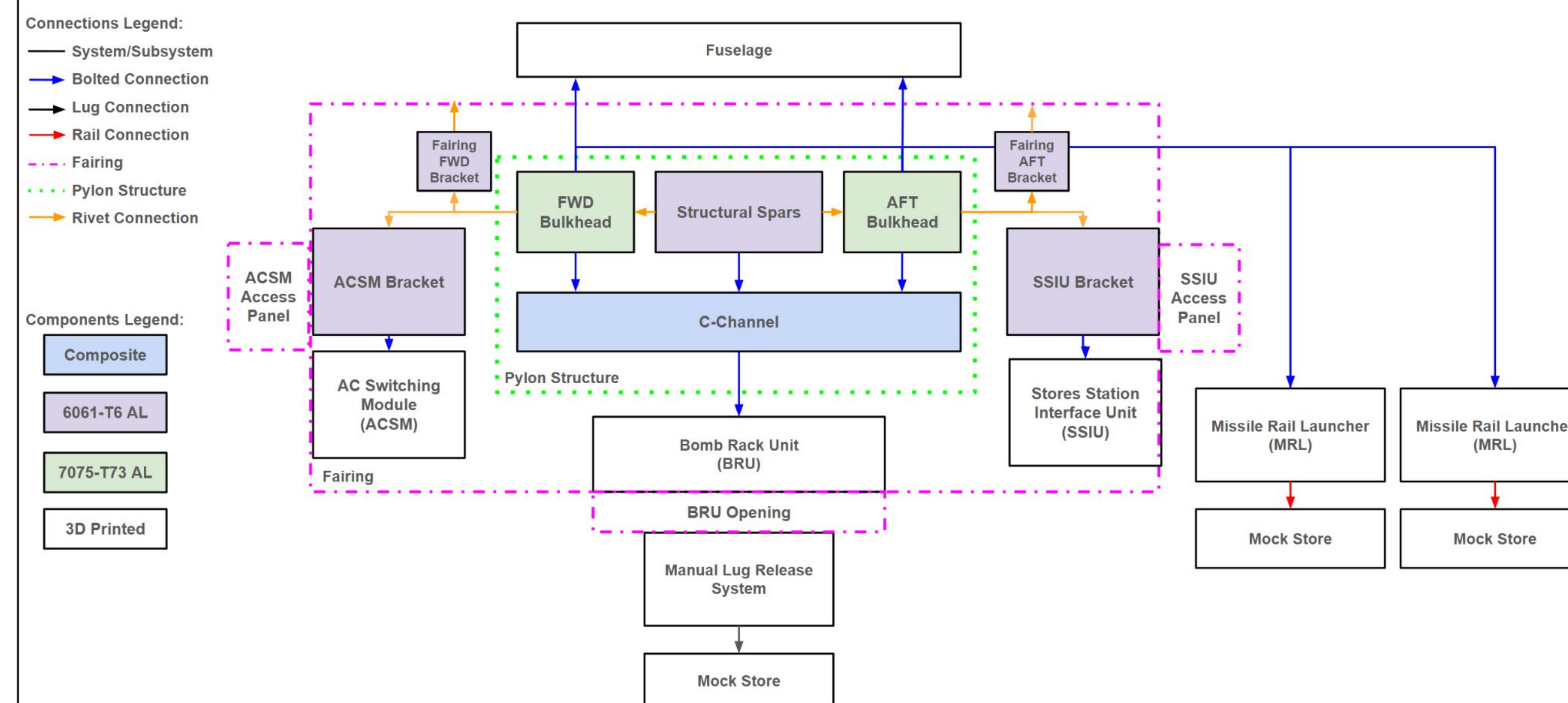

## Manufacturing/Prototyping

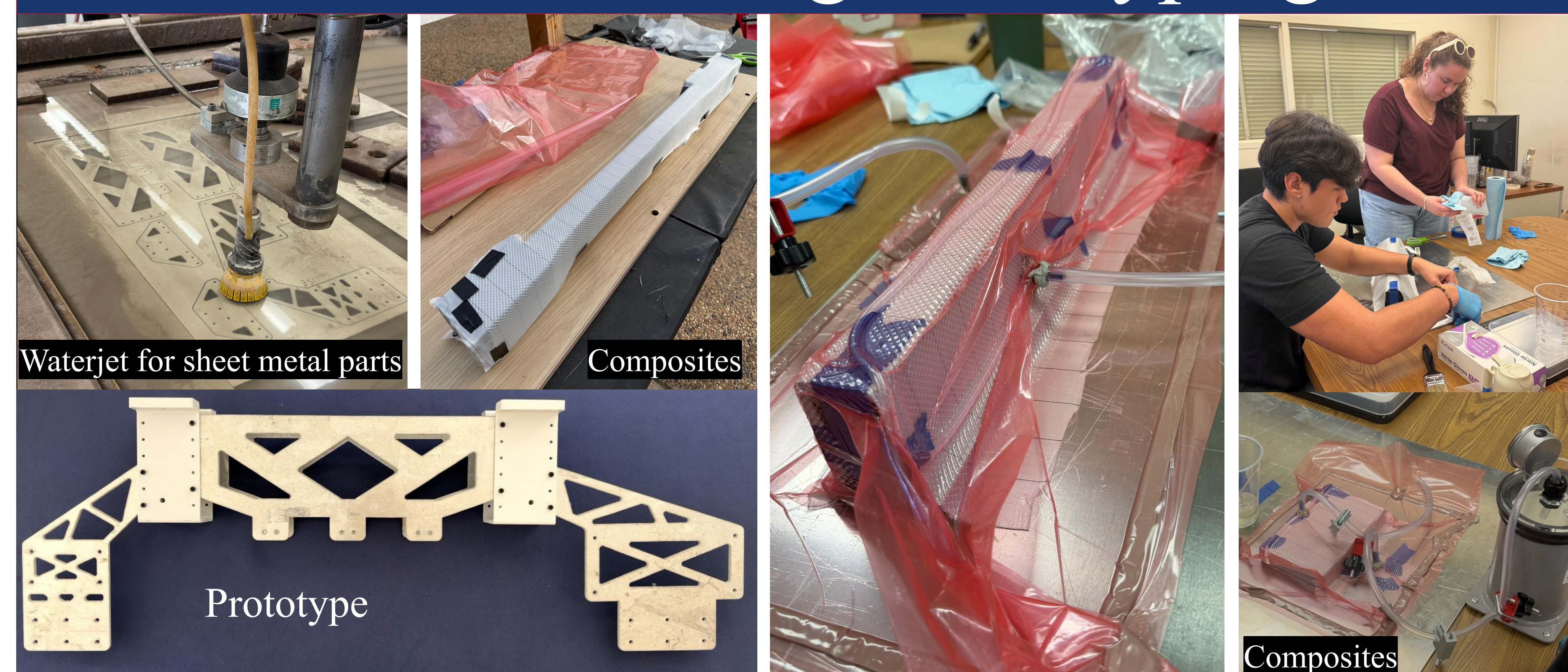

## Acknowledgements

We would like to sincerely thank Dr. Shaffar for his guidance and support throughout this project. We also extend our gratitude to our General Atomics sponsor team for their invaluable mentorship and assistance, including Christopher Aguilar, Tallon McDonough, Christopher Sam, Eshan Sinha, and Kristopher Russell.

## Static Structural FEA

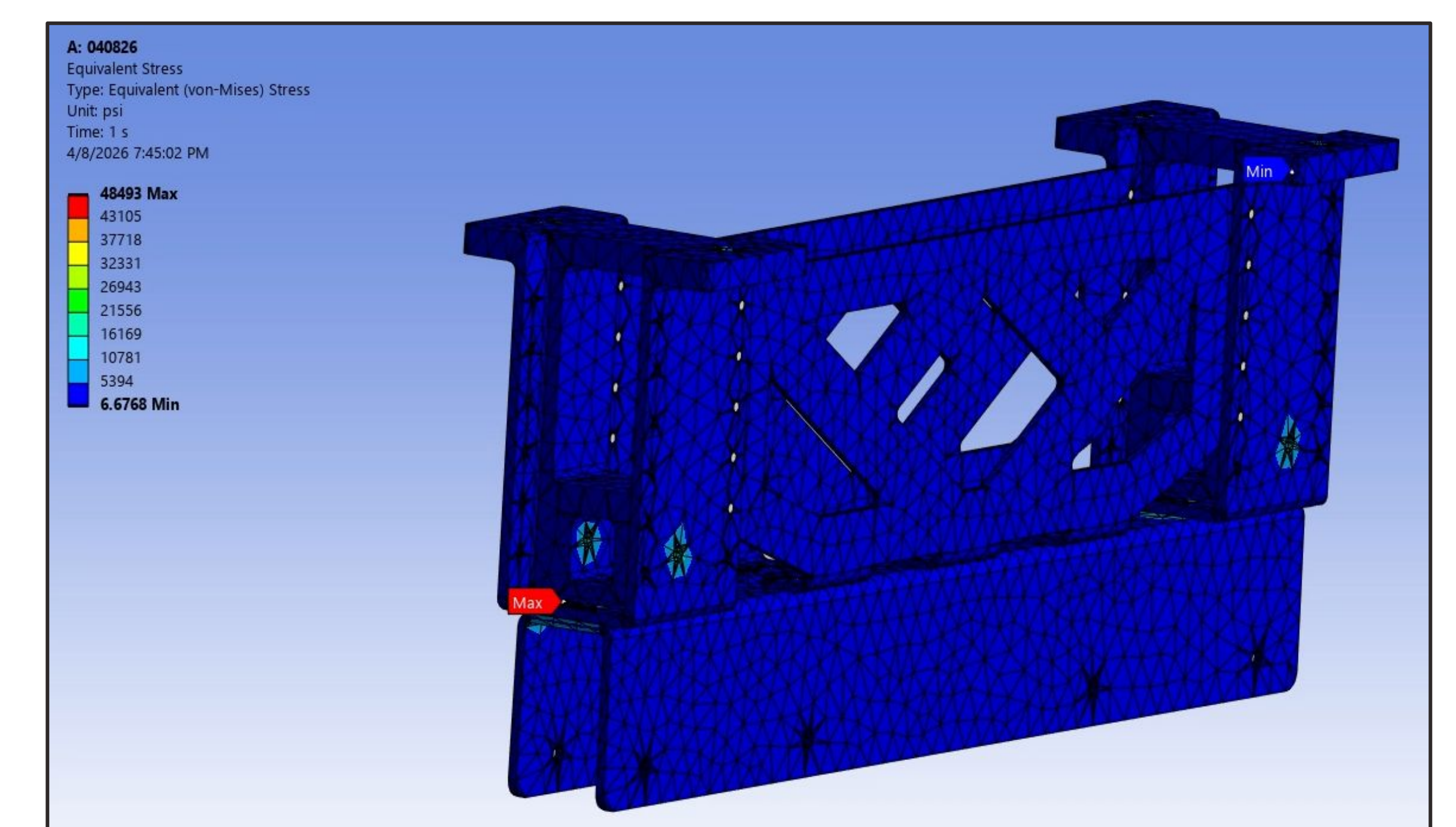

Equivalent Von Mises Stress on Pylon Assembly

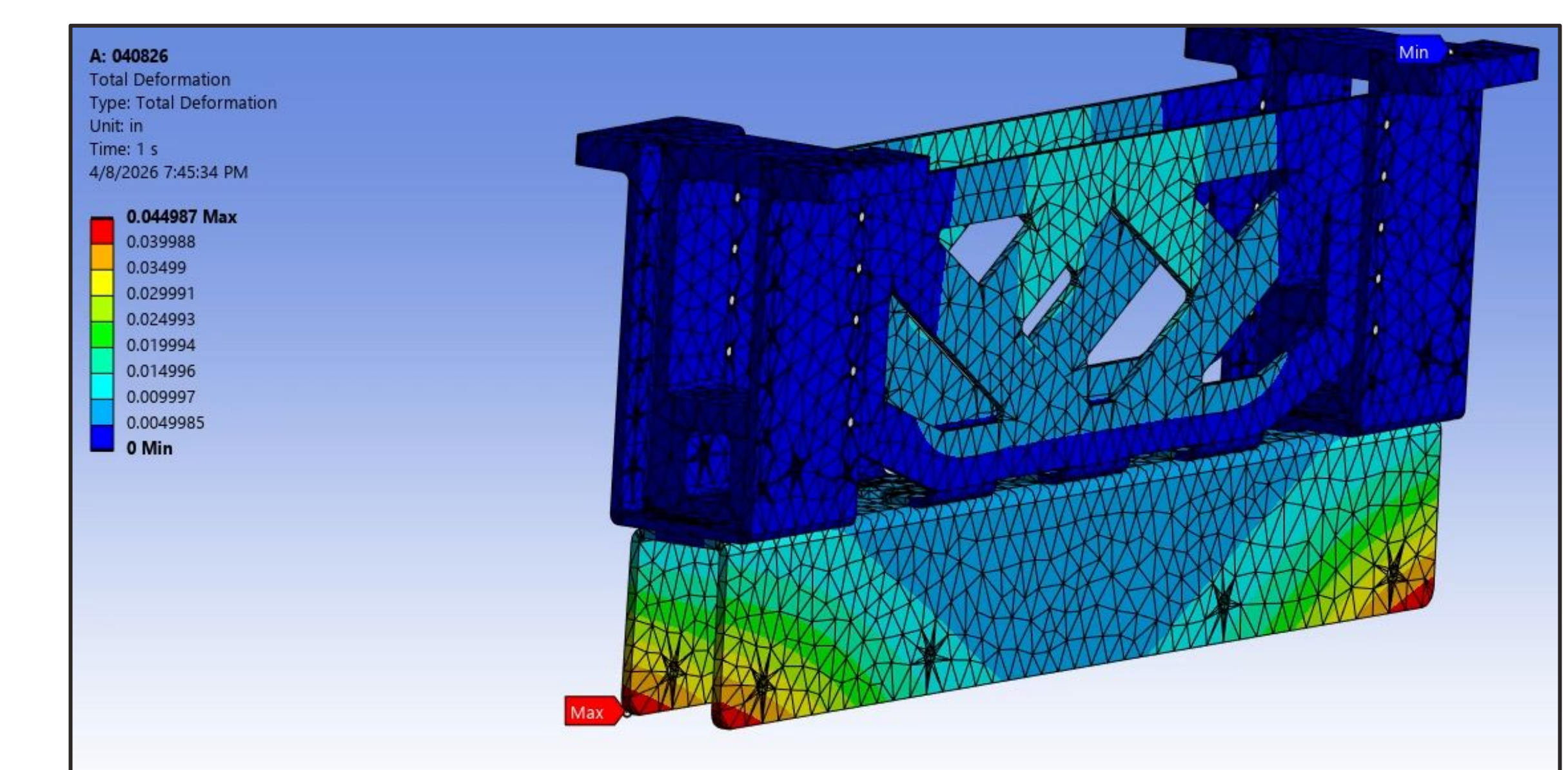

Total Deformation of Pylon Assembly