



Project Overview

This project is a student competition focused on designing and building fully 3D-printed airplanes that are lightweight and high-performing while meeting specific material and manufacturing constraints. All structural components must be additively manufactured, challenging teams to integrate design and production effectively and innovate within the limits of 3D printing.

The competition includes separate flight and design categories and aims to give students hands-on experience with digital manufacturing and aerospace engineering. Cloud 9's plane will be tested in competition at Cal State LA on May 30th

CAD Model

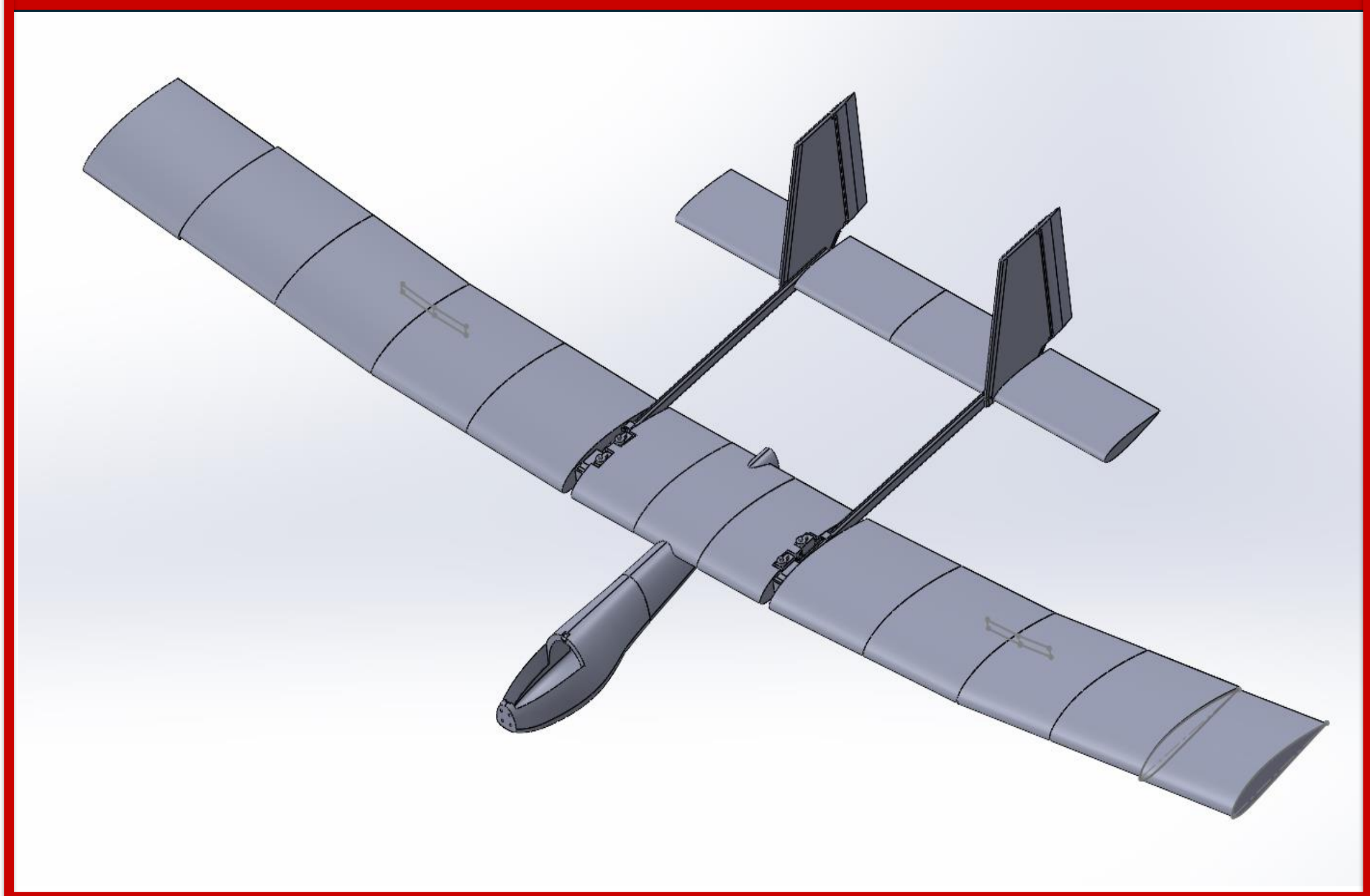

CAD Exploded Views

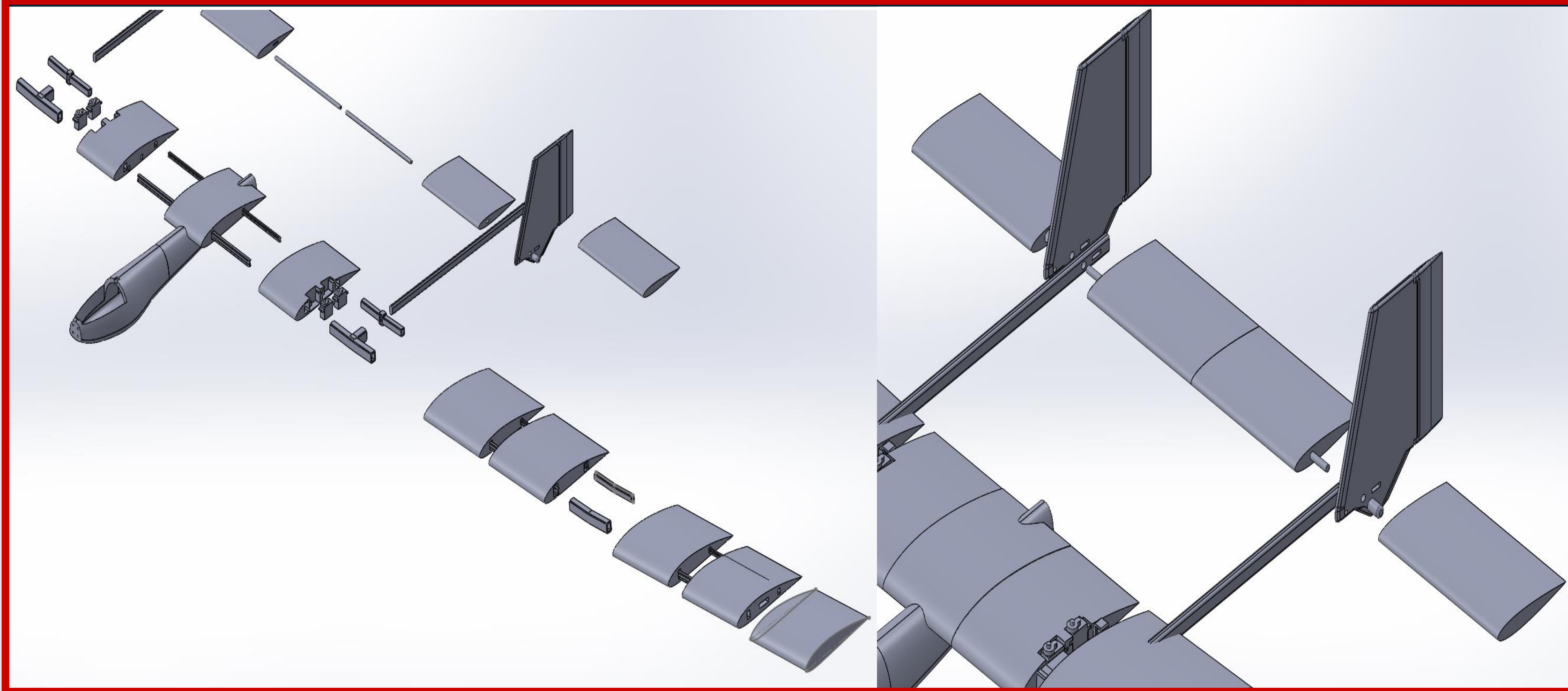

Meet Cloud 9

 Joshua Cain Mechanical Engineer	 Kole Christoff Mechanical Engineer	 Corbin Paull Mechanical Engineer
 Alan Brockmeyer Mechanical Engineer	 Jack Wise Mechanical Engineer	 Andrew McGlynn Aerospace Engineer
 Brendan Scharmann Aerospace Engineer	 Hayden Schmehl Aerospace Engineer	 David Maturin Aerospace Engineer

Testing and Analysis

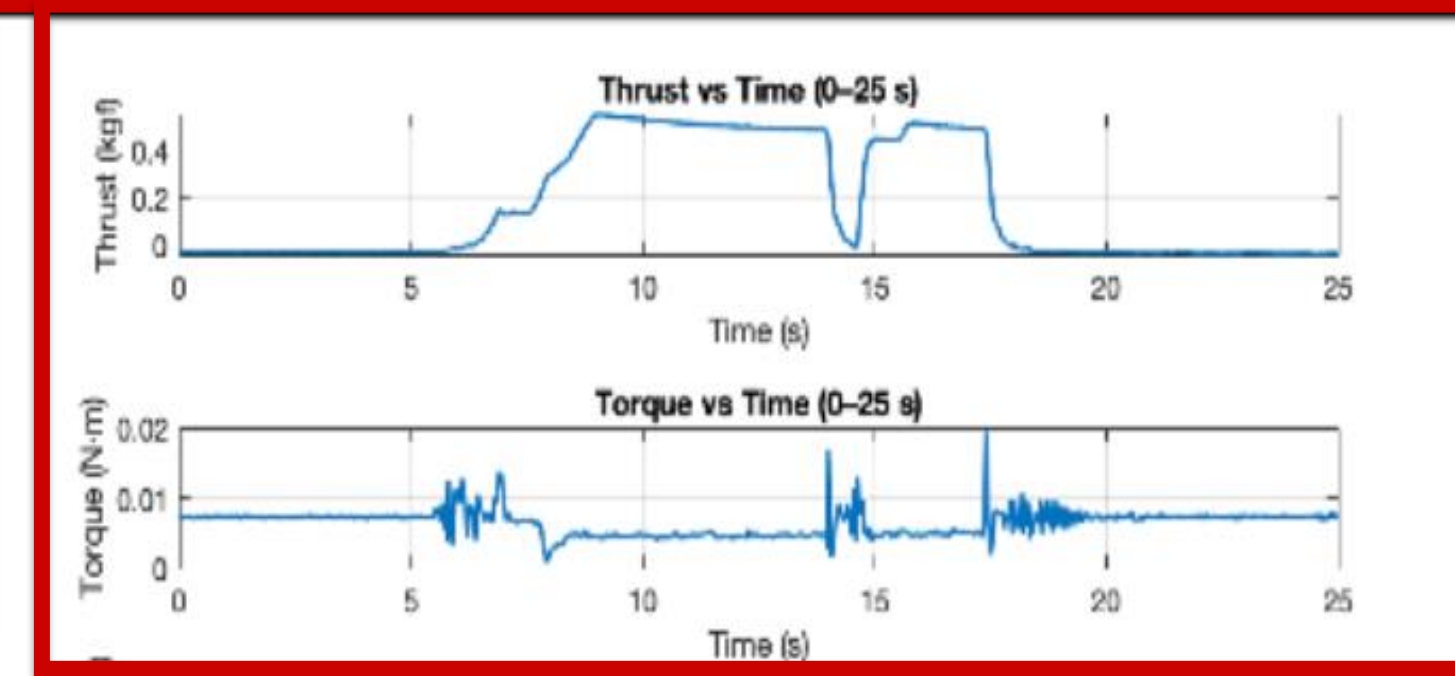
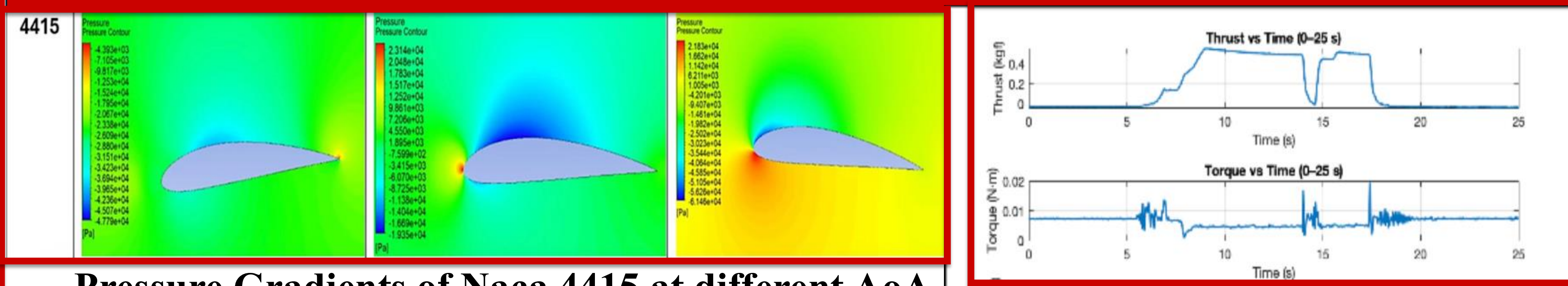

Prototypes

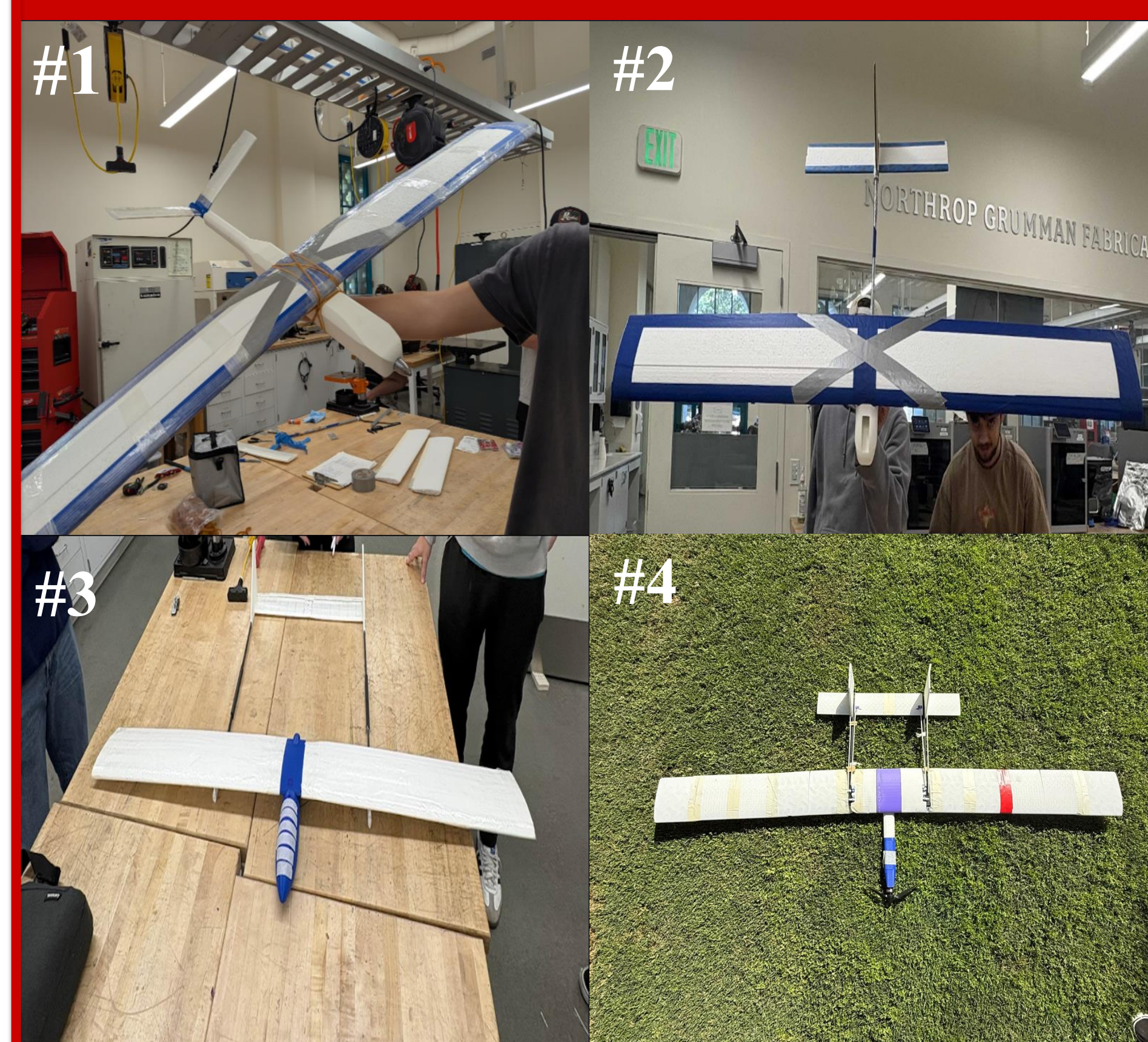

Manufacturing

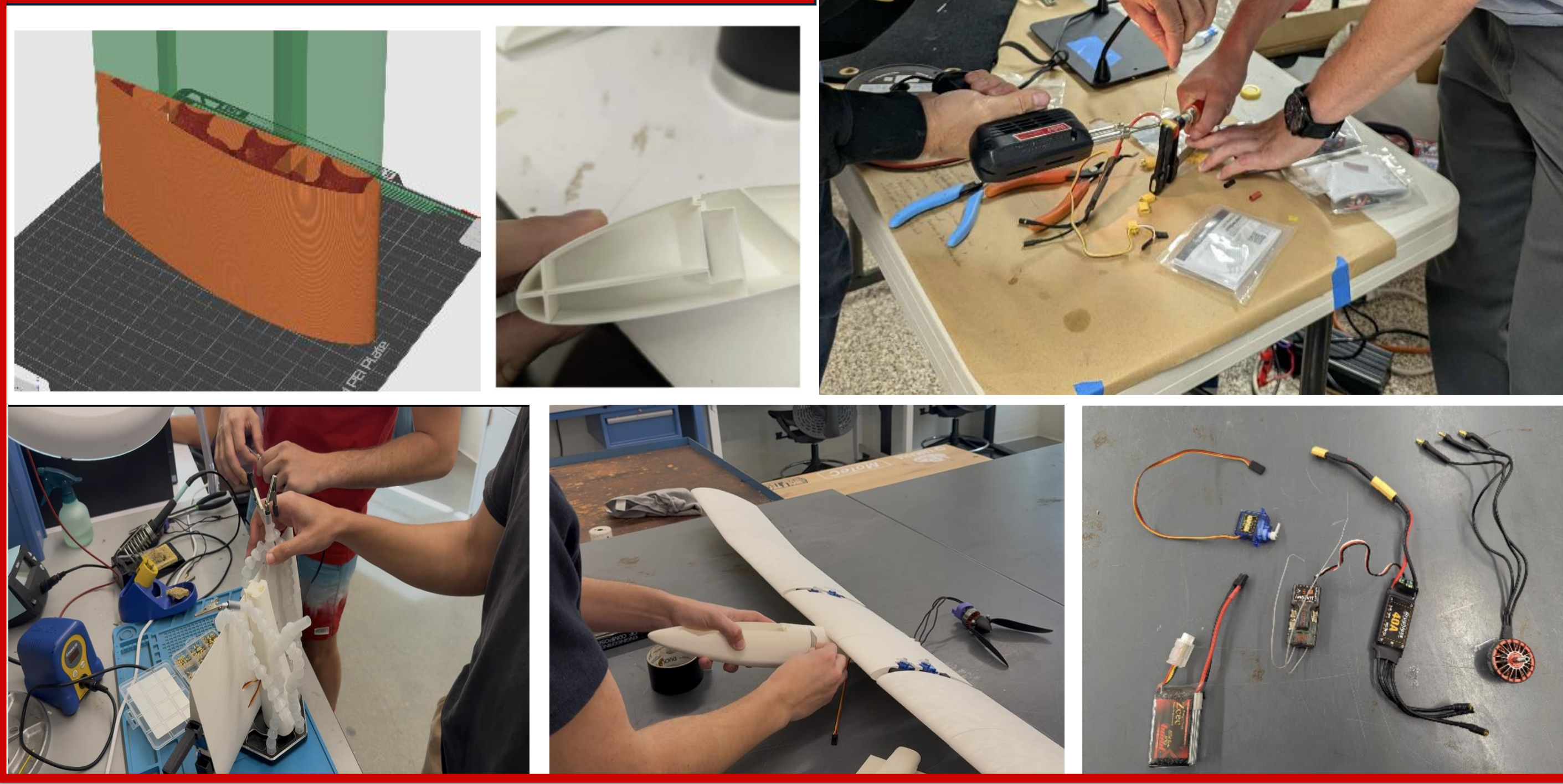

System Level Diagram

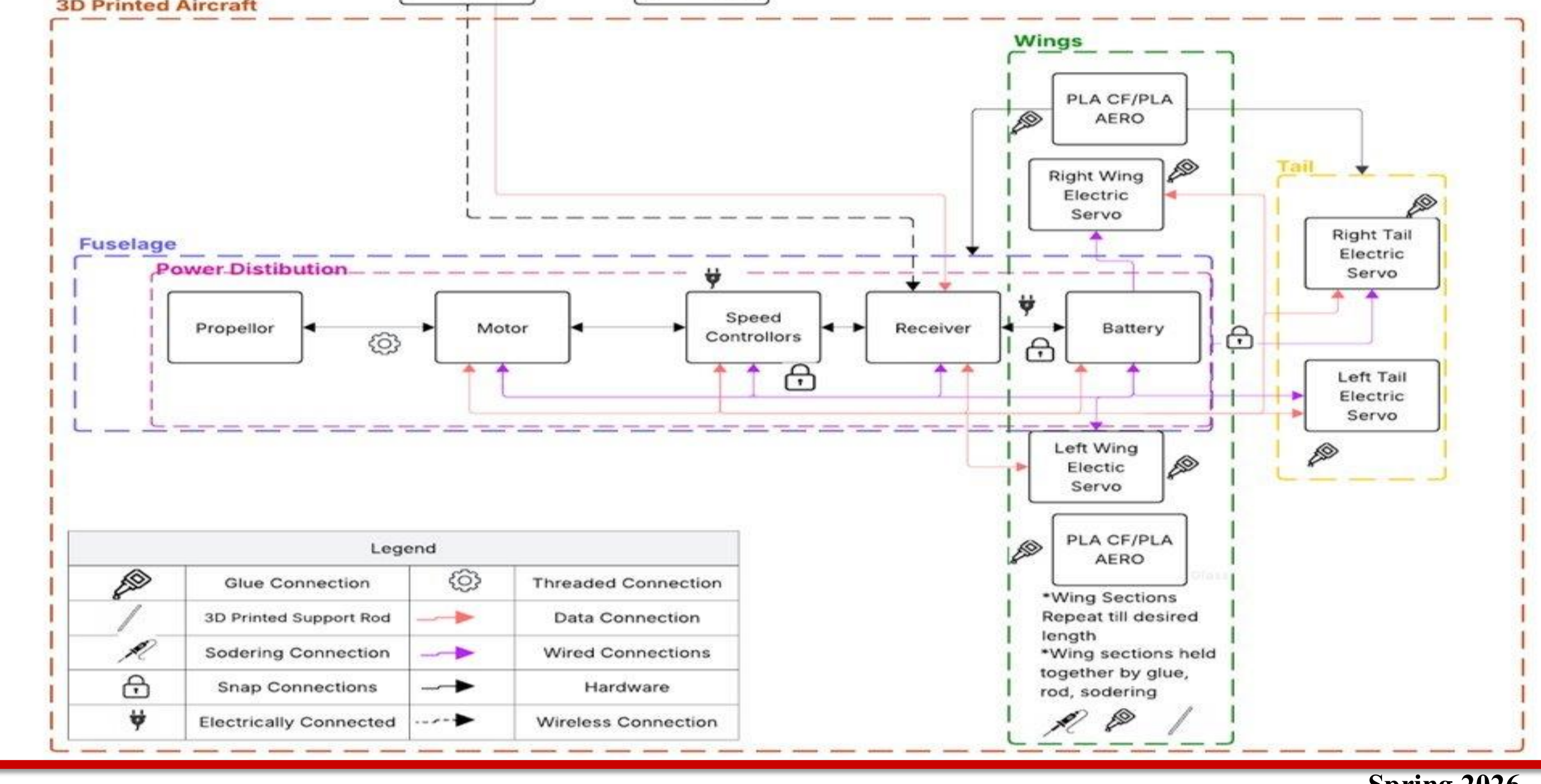

Acknowledgements

Cloud 9 extends our sincere gratitude to our sponsors and mentors Dr. Scott Shaffer, Dr. Geoffery Butler, Oscar Correa, Charles (Chuck) Norris, and Matthew Owens, whose guidance and support made this project possible. We also thank our project donors and the San Diego State University Mechanical Engineering Department for providing access to their facilities for design, testing, and manufacturing.