

## Project Overview

The project improved the Revolution 500 SC's aerodynamic performance by redesigning its components. The team analyzed the existing wing, developed CAD models, performed FEM and CFD analyses, and validated results through track testing. The final design used lightweight, high strength carbon fiber and adjustable aluminum ribs to optimize angle of attack, with performance assessed through tuft testing, lap times, top speed, sensor data, and driver feedback. Deliverables included two rear wing iterations, front splitter winglets, and integrated tire and suspension sensors.

## Computer Aided Design

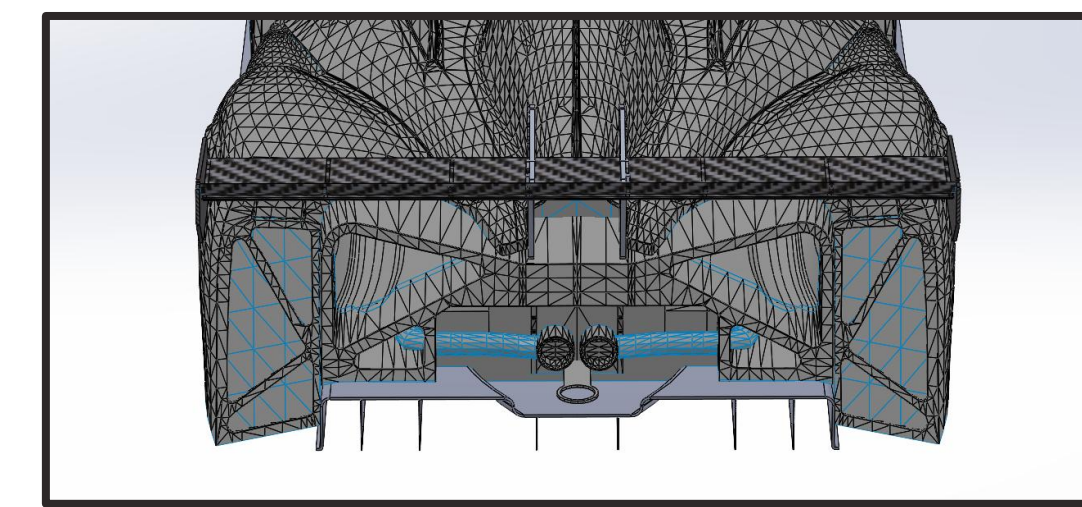
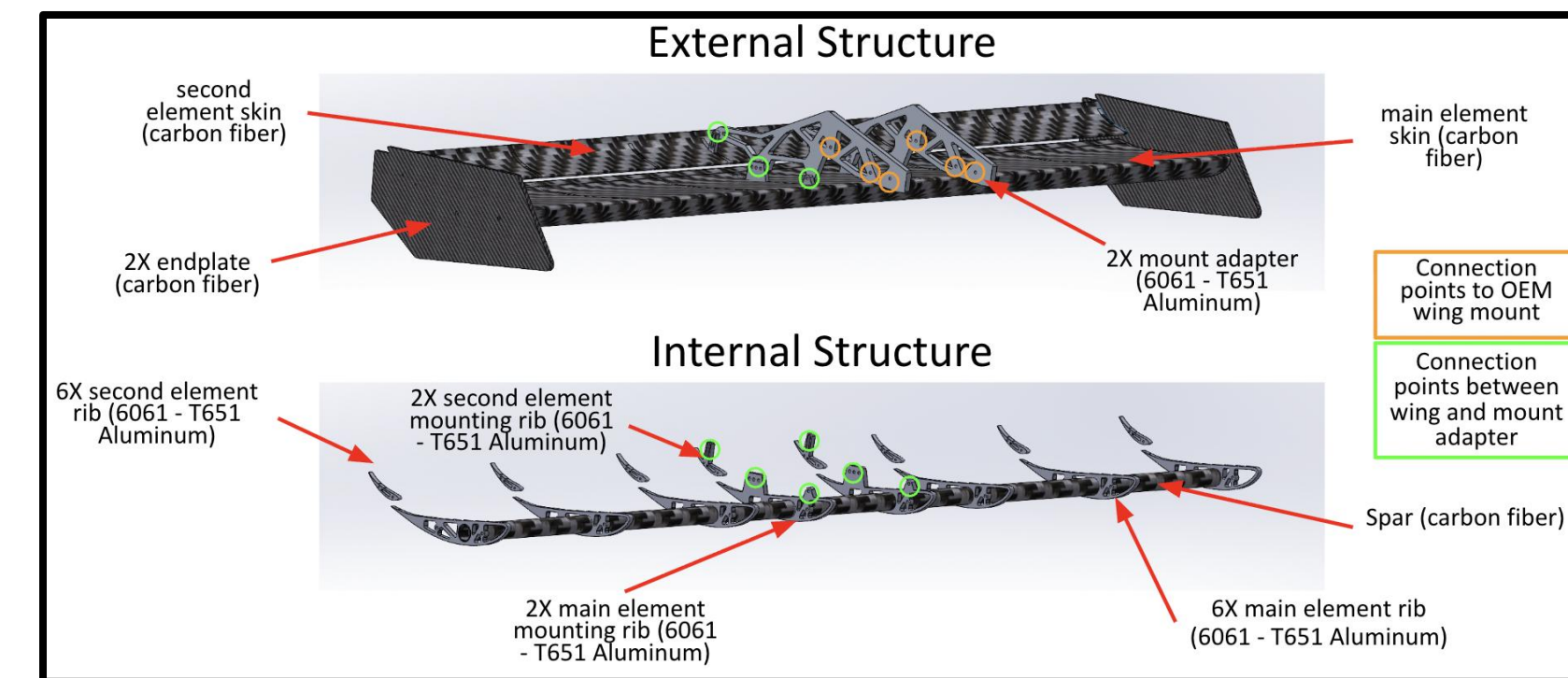

V1 Rear Wing Backside

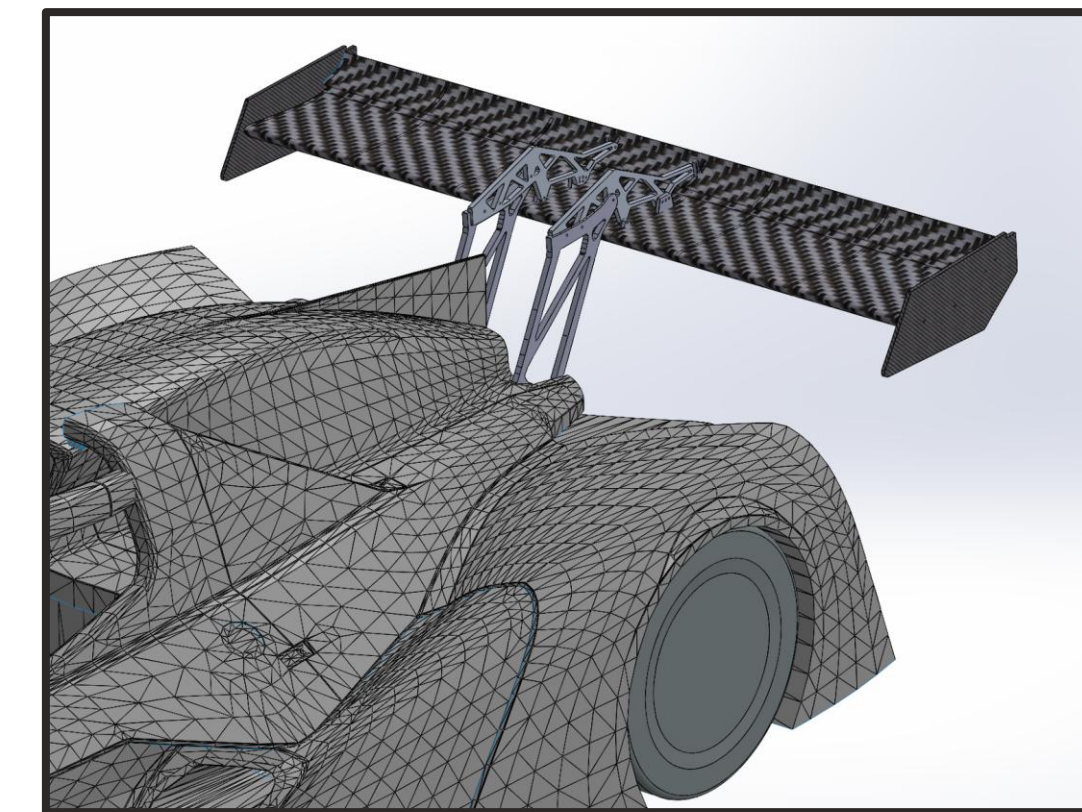
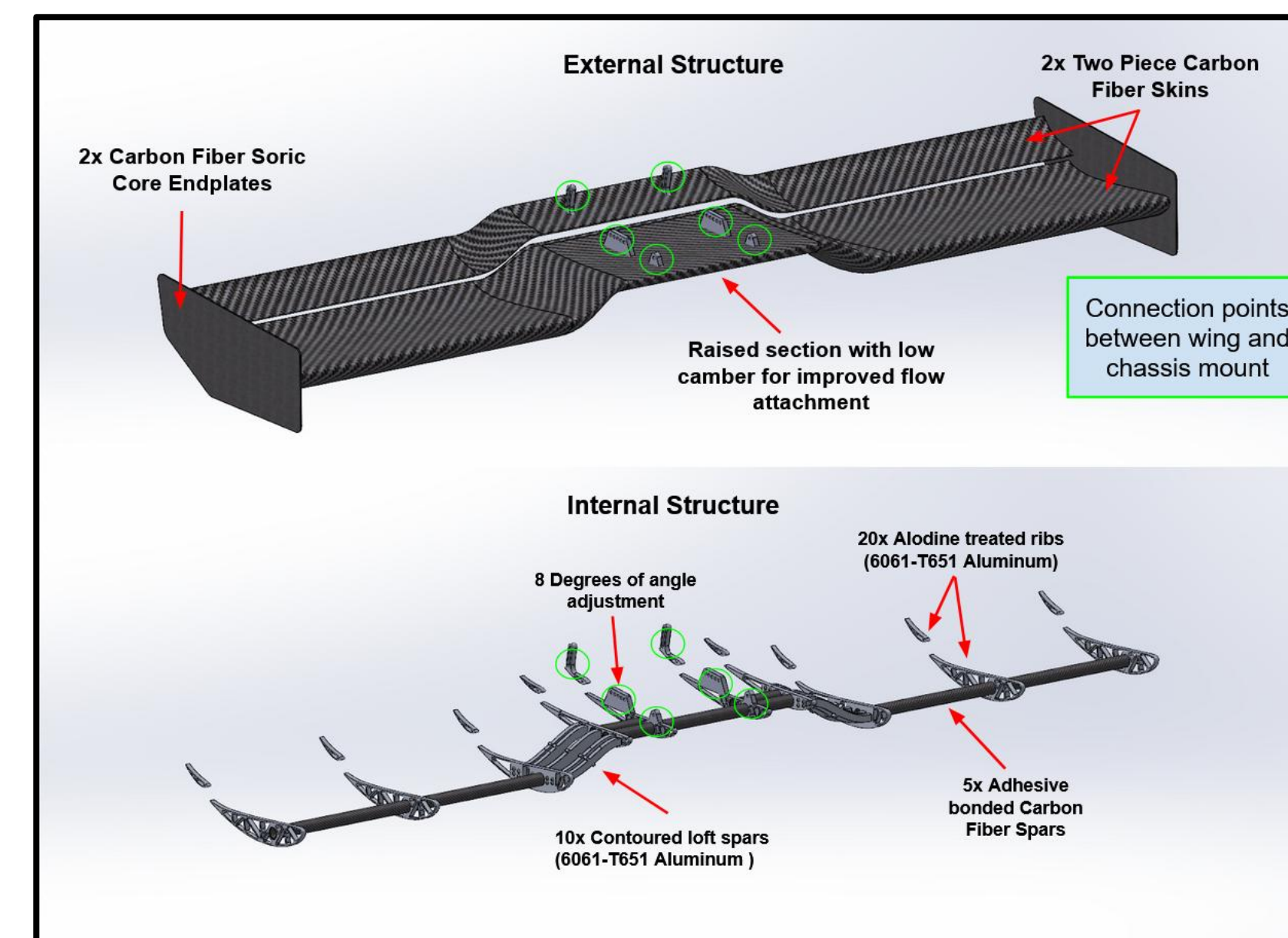

V1 Rear Wing Isometric

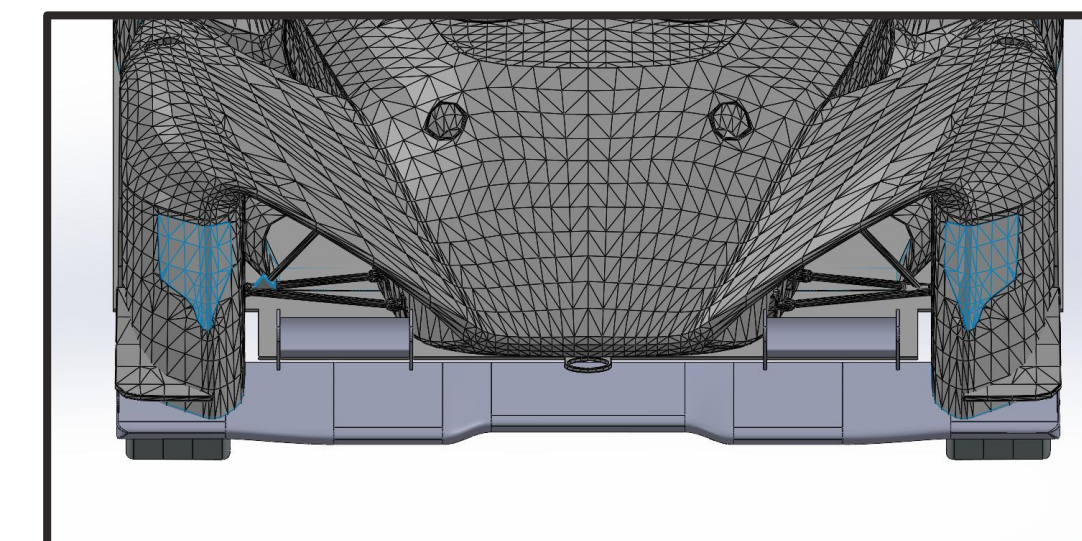

Front Splitter

## Analysis

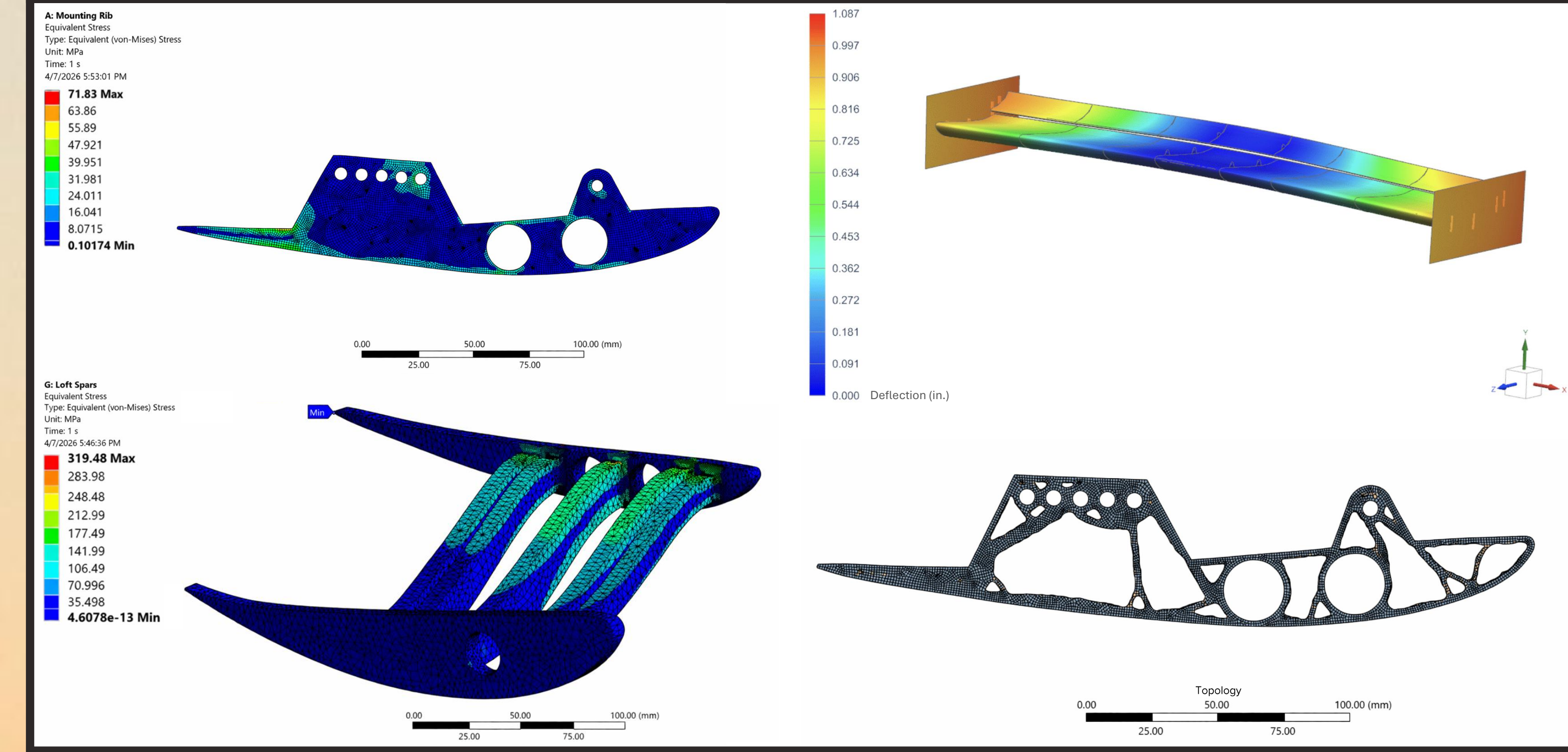

## Meet The Team

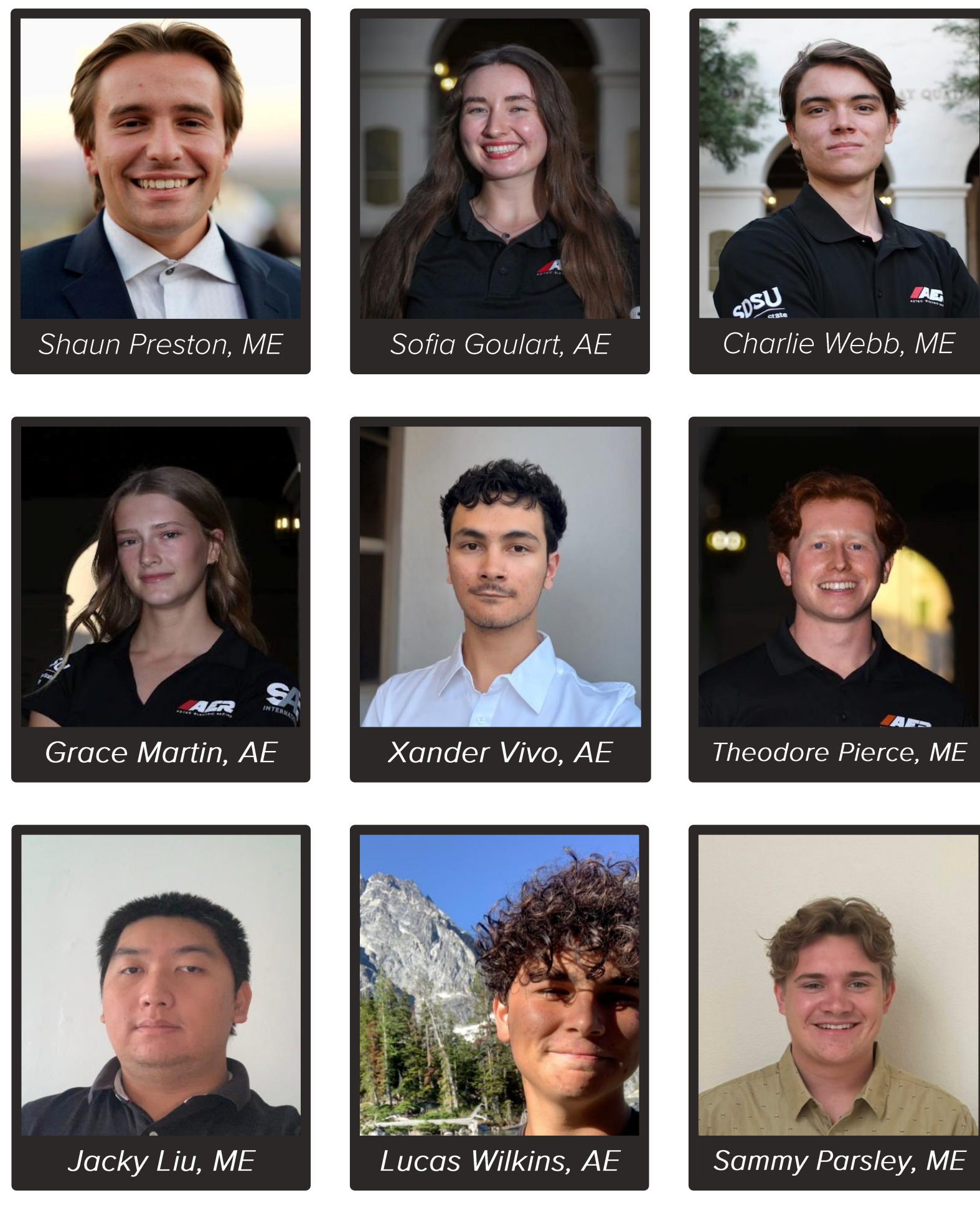

## Computational Fluid Dynamics

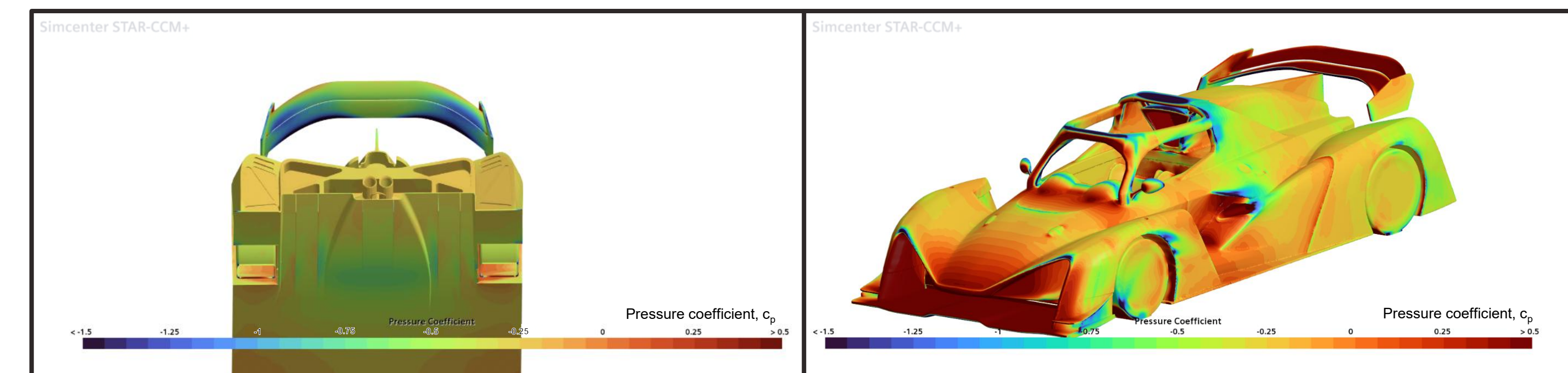

OEM Rear Wing

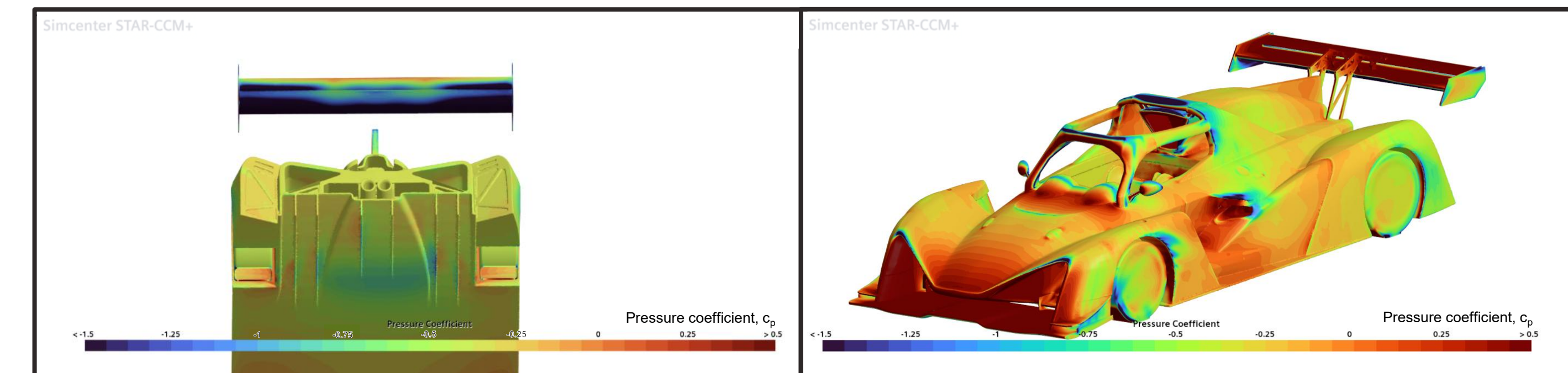

V1 Rear Wing

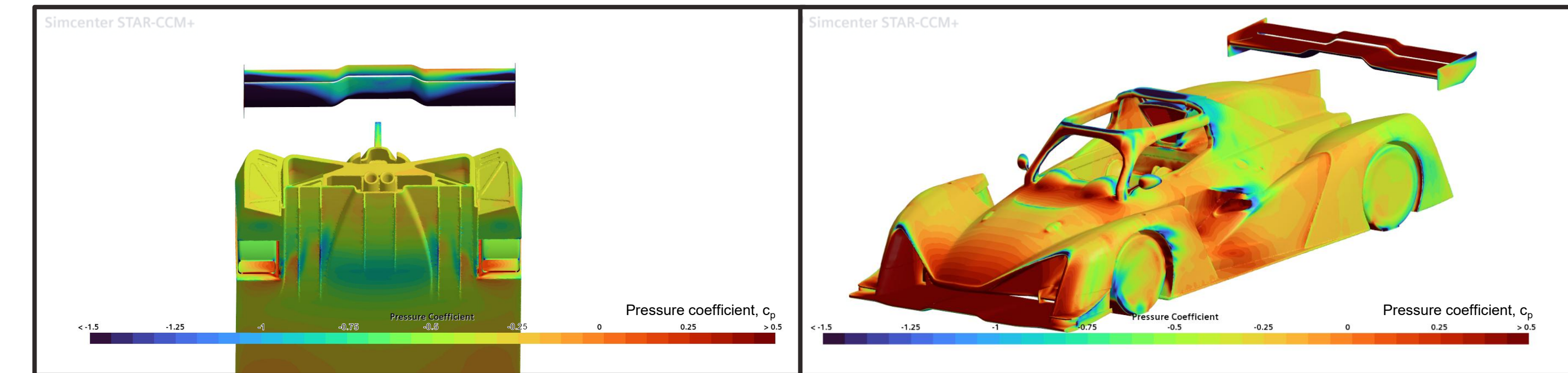

V2 Rear Wing

## Testing



## Fabrication

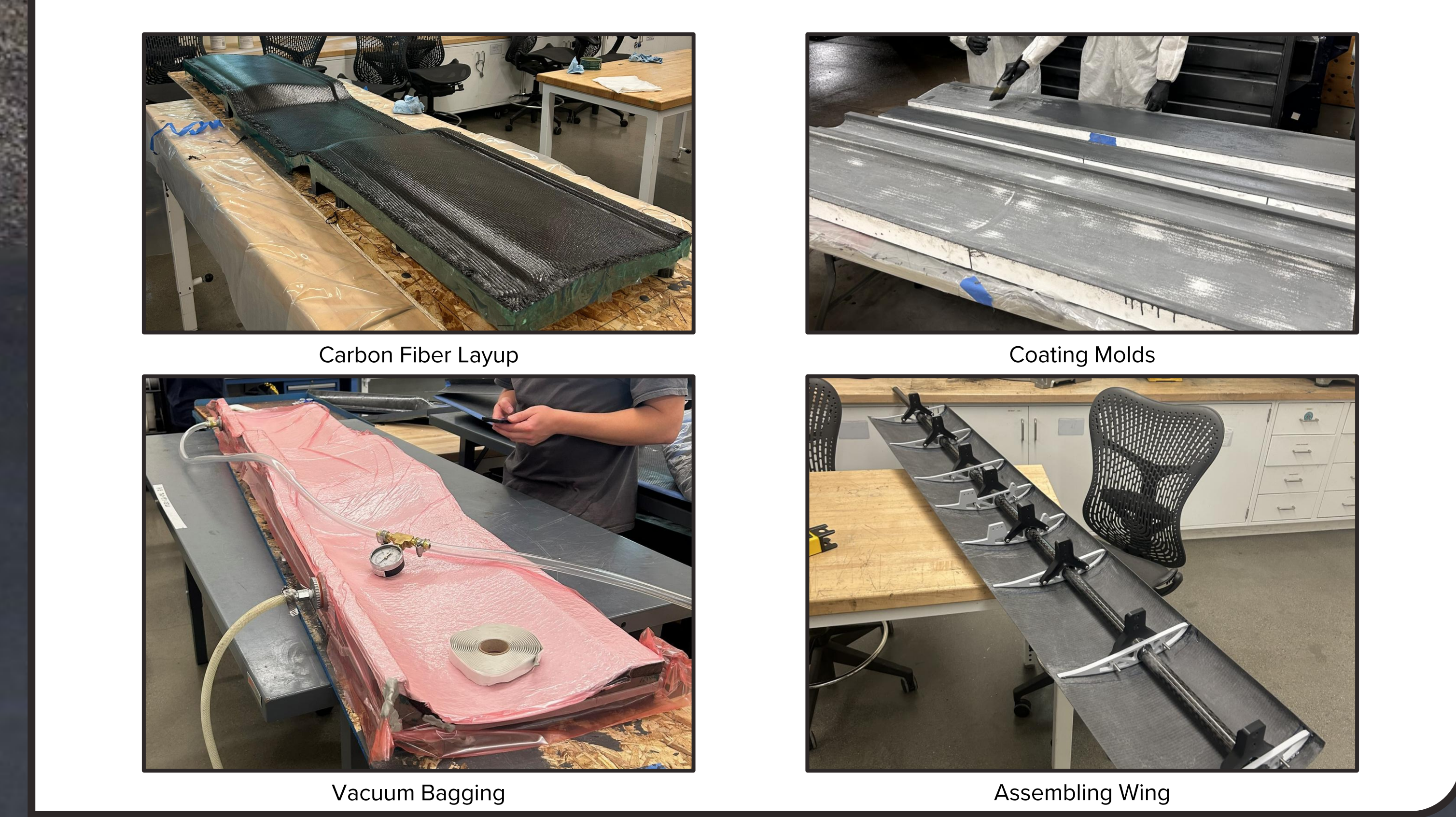

## Acknowledgements

The Team would like to thank Dr. Scott Shaffar for arranging and advising this project along with Dr. Joseph Katz and Dr. Roni Goldshmid. We would like to thank our sponsor, Ron Fletcher, for his contributions and support throughout the project along with his mechanic, Jason Miles, for his extensive insight on track testing.