



Project Overview and Motivation

The Robotic Palm Tree Trimmer is a remote controlled robot designed to climb palm trees in order to cut dead fronds. The purpose of this project is to reduce injuries and fatal accidents during palm tree trimming. This is a continuation project going on its third year of improvement. This year, the focus is a redesign of the upper stage platform, track, and the traction arms. As well as to address issues of climbing and moving the circumferential platform around the track.

Meet the Sponsor

Max Marek Winiarz is a retired engineer and founder of Max Engineering, an entity dedicated to pursuing innovative engineering projects driven by passion and purpose. One of his key initiatives is the development of a robotic palm trimmer with the vision of saving lives by enhancing the safety and efficiency of palm tree maintenance, also helping towards the prevention of wildfires.



Max Marek Winiarz
Project Sponsor

Meet Team Mechatronics



Lukas Hruza ME Lead
Alyssa De La Torre Engineering Manager
Christian Montano Manufacturing Engineer
Andres Santos ME Quality Engineer
Esha Ram Safety Engineer



Daniel Cueva ECE Lead
Kanji Hirayama Lead Test Engineer
Coltin Haniotakis Wiring Logistics Engineer
Nicolas Armenta Machine Code Engineer
Kevin Lee Controller Code Engineer

Conclusion

Over the course of this project, the upper stage and traction arms were redesigned. Additionally, key power issues were diagnosed and handled mechanically by improving the gear ratio rather than seeking a new power supply. The inconsistent behaviour of the wireless controller (previously a bare PCB) has been resolved with a newly designed and 3D printed case.

Testing and Verification

Electrical testing was performed to get voltage and current traces from the motors to formulate a better understanding as to why the machine was not climbing. Necessary component wiring and a climbing test can be seen below.

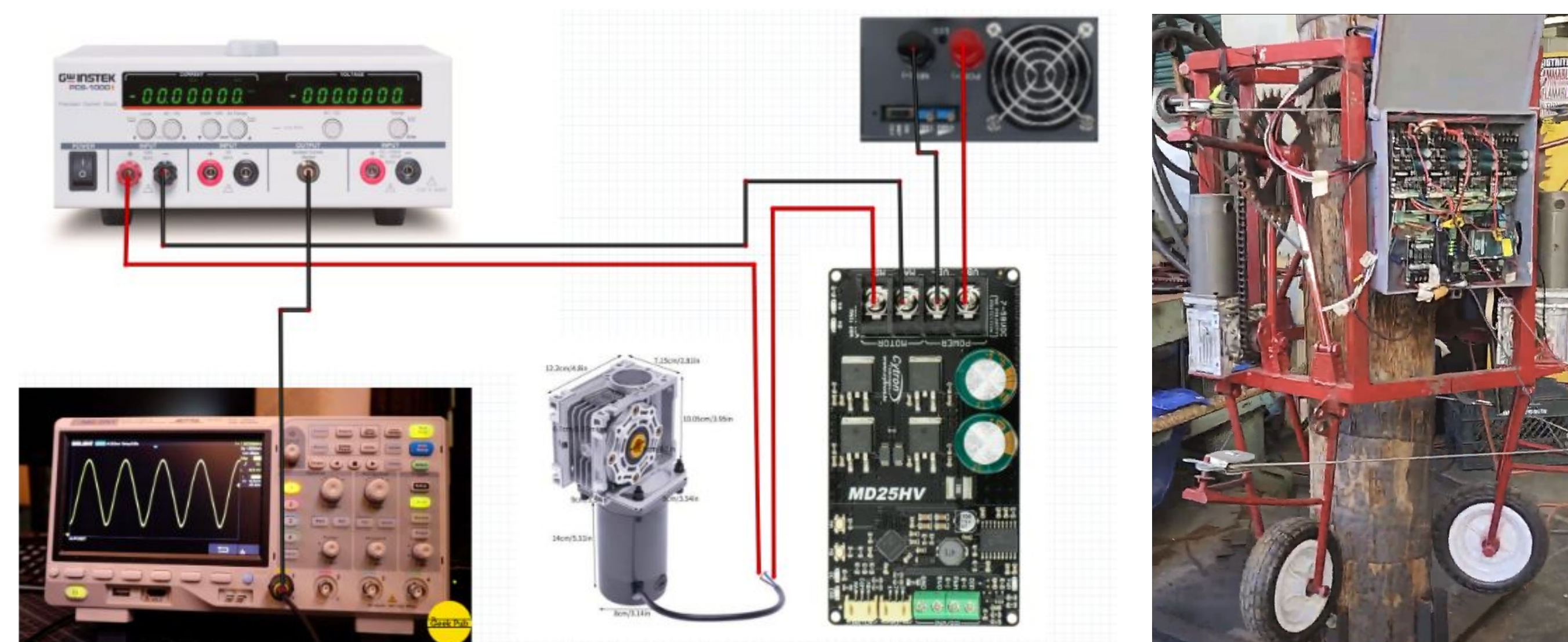

Wiring Diagram

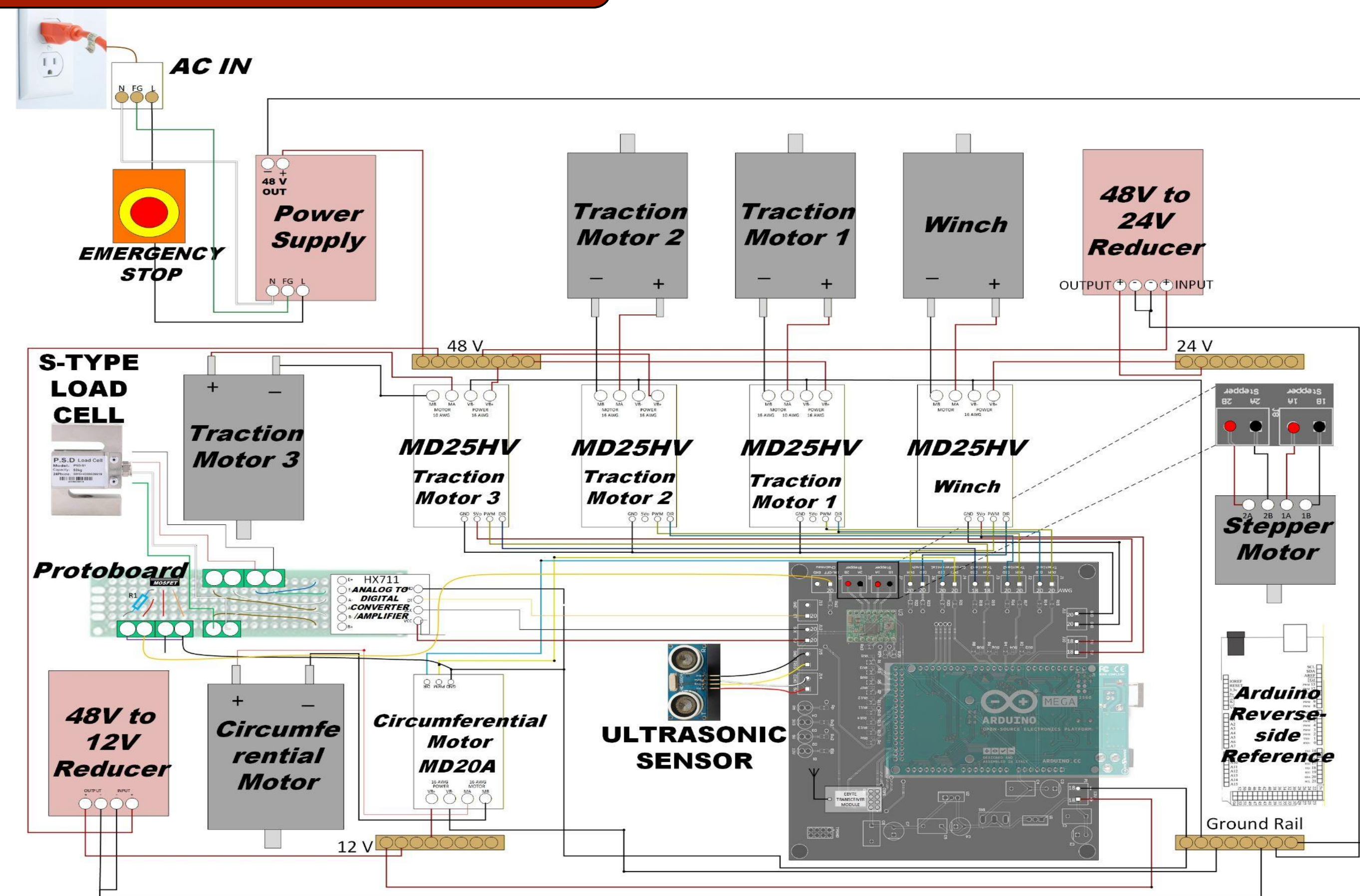

System Diagram

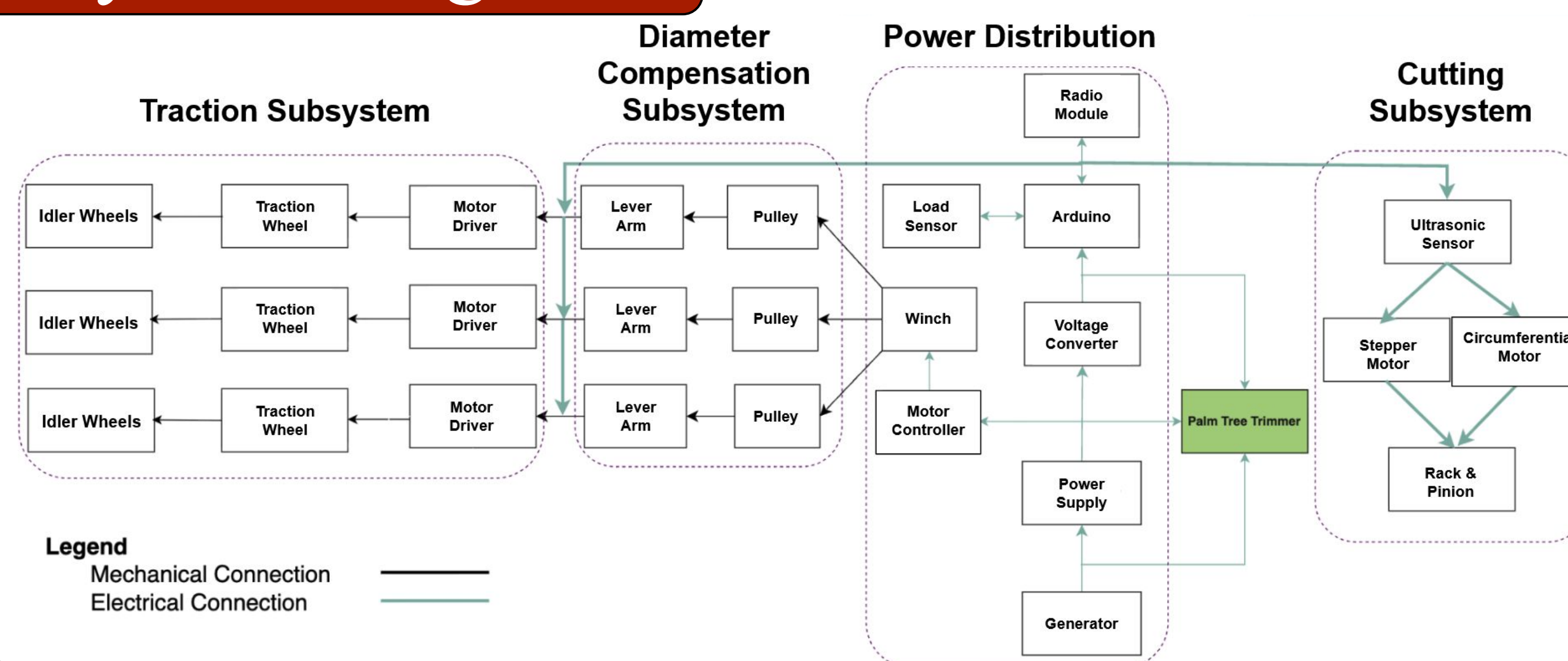

CAD Design

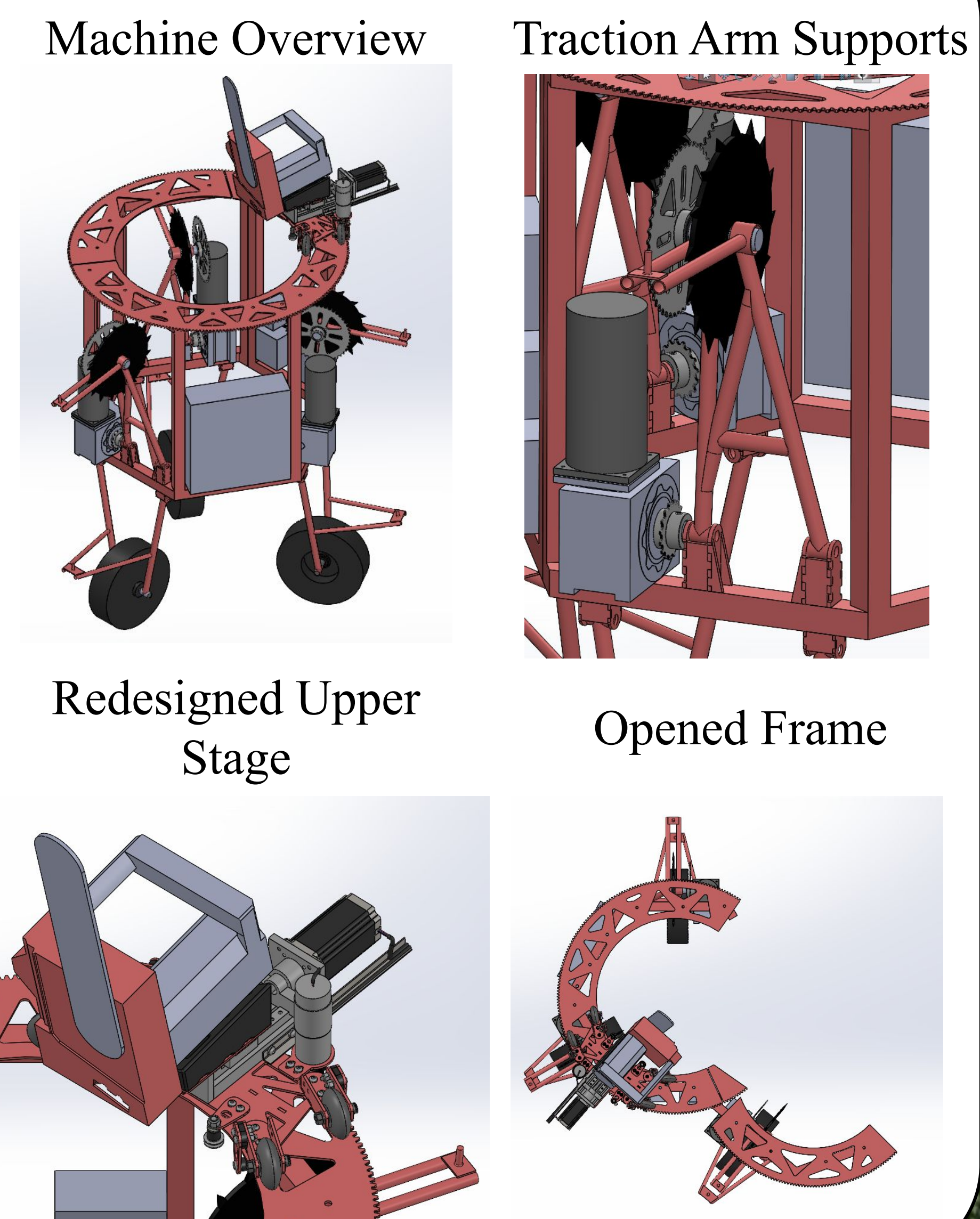

Controller

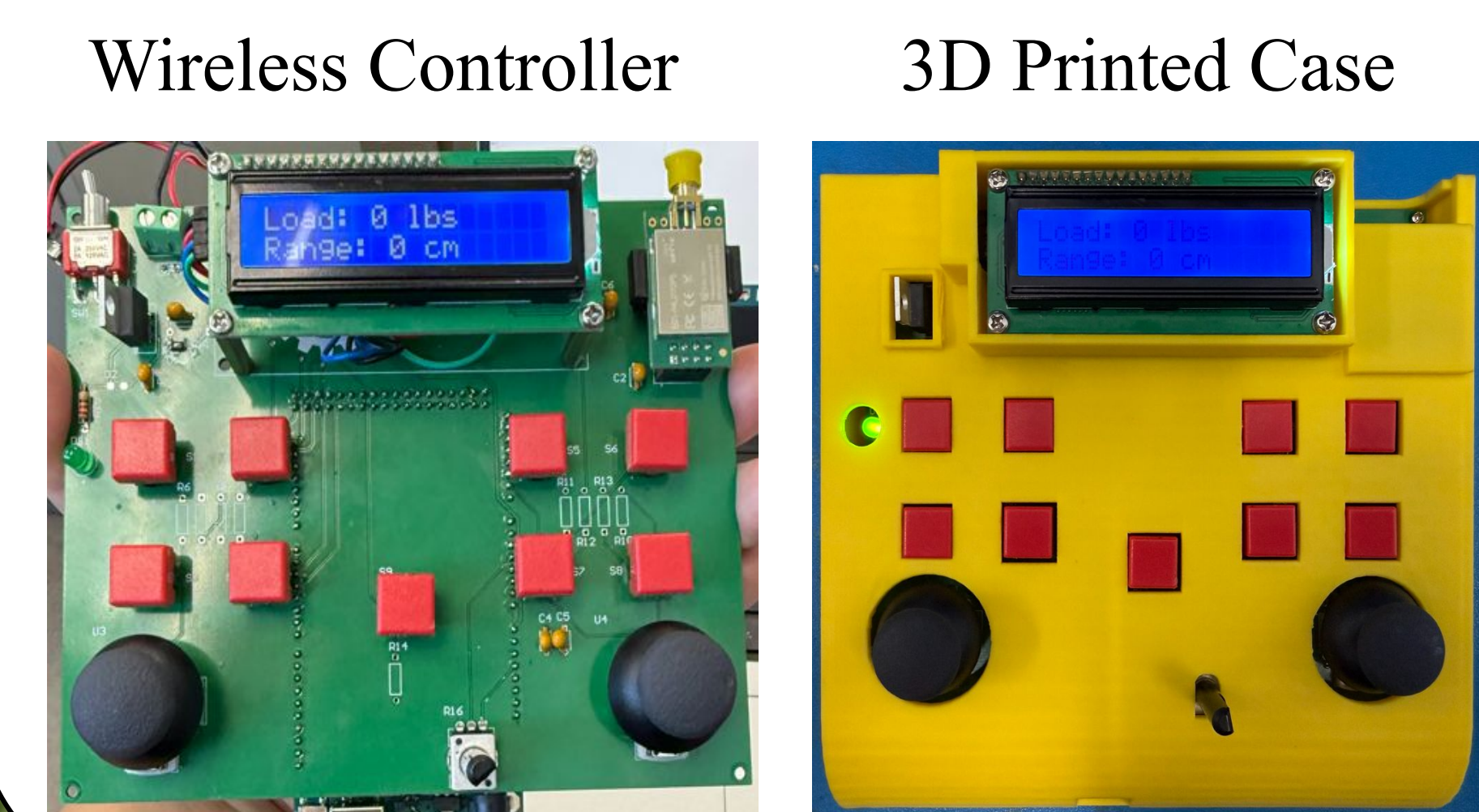

Acknowledgments

We would like to extend our gratitude to the following staff for their support in the creation of our project:

Dr. Scott Shaffar, Professor Christopher Paolini, Professor Barry Dorr, Mr. Max Marek Winiarz, Mr. Mark Bruno, Mr. Tu Nguyen, Mrs. Louisa Burrus, Ms. Selena Jarin