

Palm Platform - Vertical Transport Elevator



Project Overview

Palm Platform - Vertical Transport Elevator is an unmanned, remotely operated device. This system aims to get tree trimmers off of fan palms and perform the tree trimming operation safely from the ground.

In this project, team LV8 has tackled the first steps to this project by creating the climbing system that can scale the palm tree surface. This device functions wirelessly and is operated via remote control. The system is powered by 115VAC 60Hz and will adjust to the tree trunk diameters of 9 inches to 16 inches of the palm tree trunk.

Meet the Sponsor

Max Marek Winiarz is the owner and founder of Max Enterprise. Max strives to enhance the quality of life for tree trimmers by improving safety of the job. His idea to save the lives of many tree trimmers began as a vision which has now evolved into this design.

Meet the Team



Carl Michael Garcia
(Team Lead)



Ritish Gupta



Matthew Custodio



Lizbeth Rodriguez

System Level Diagram

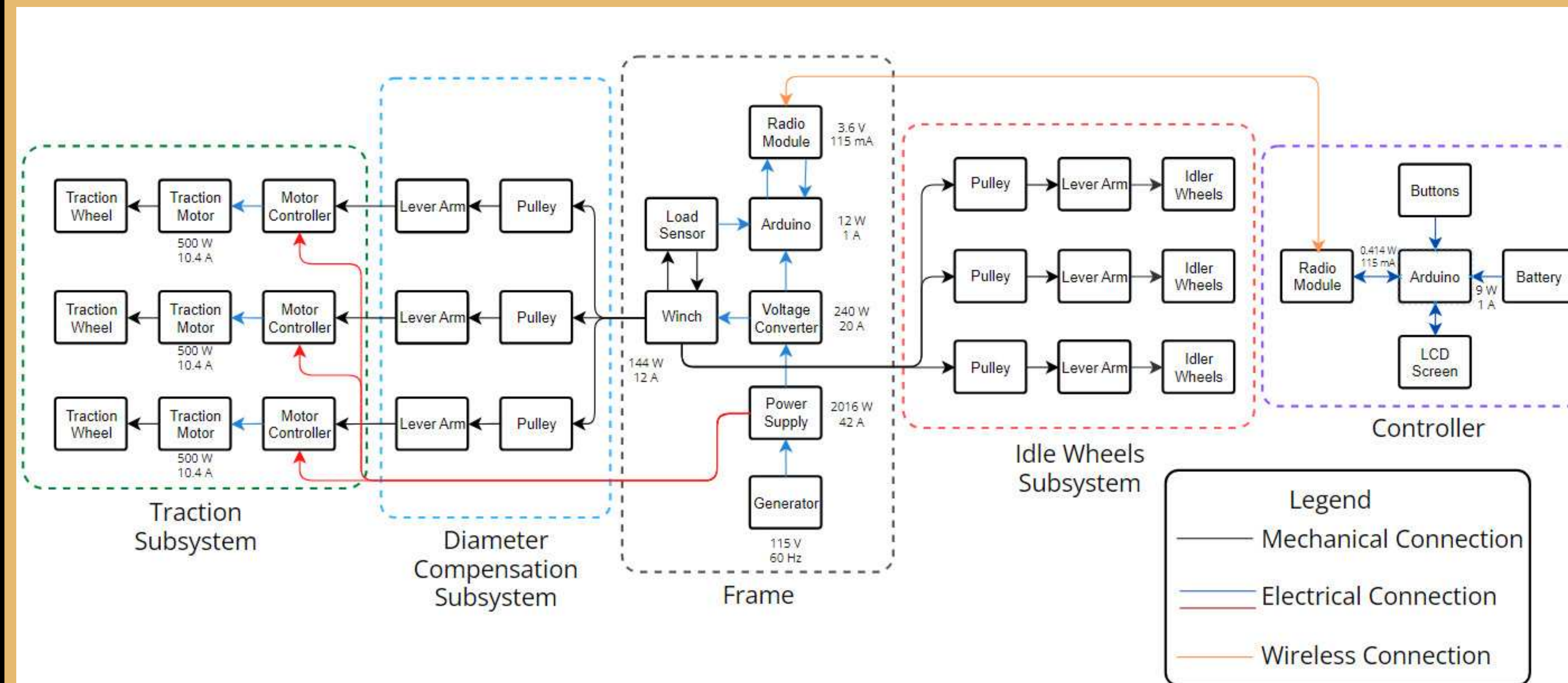

Testing

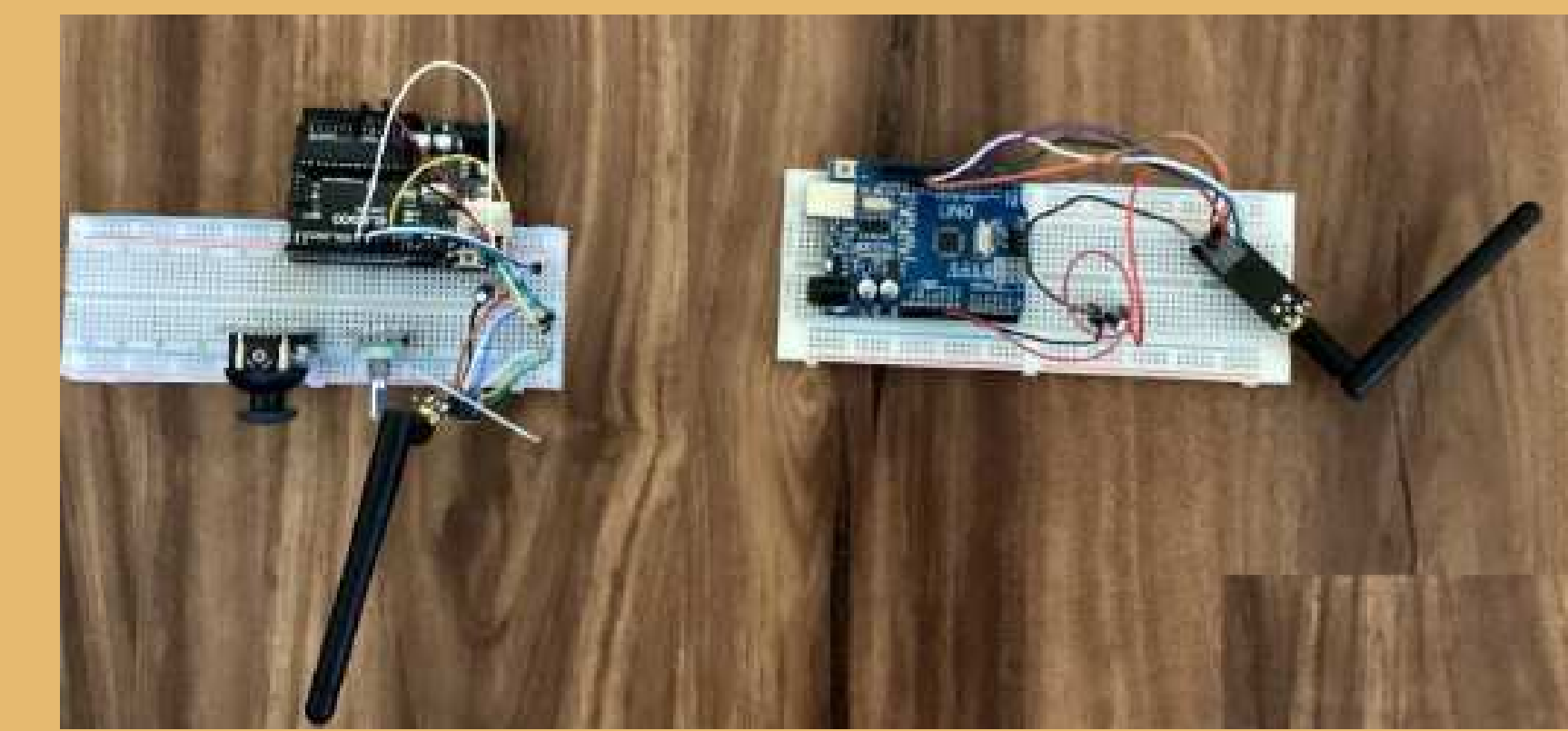
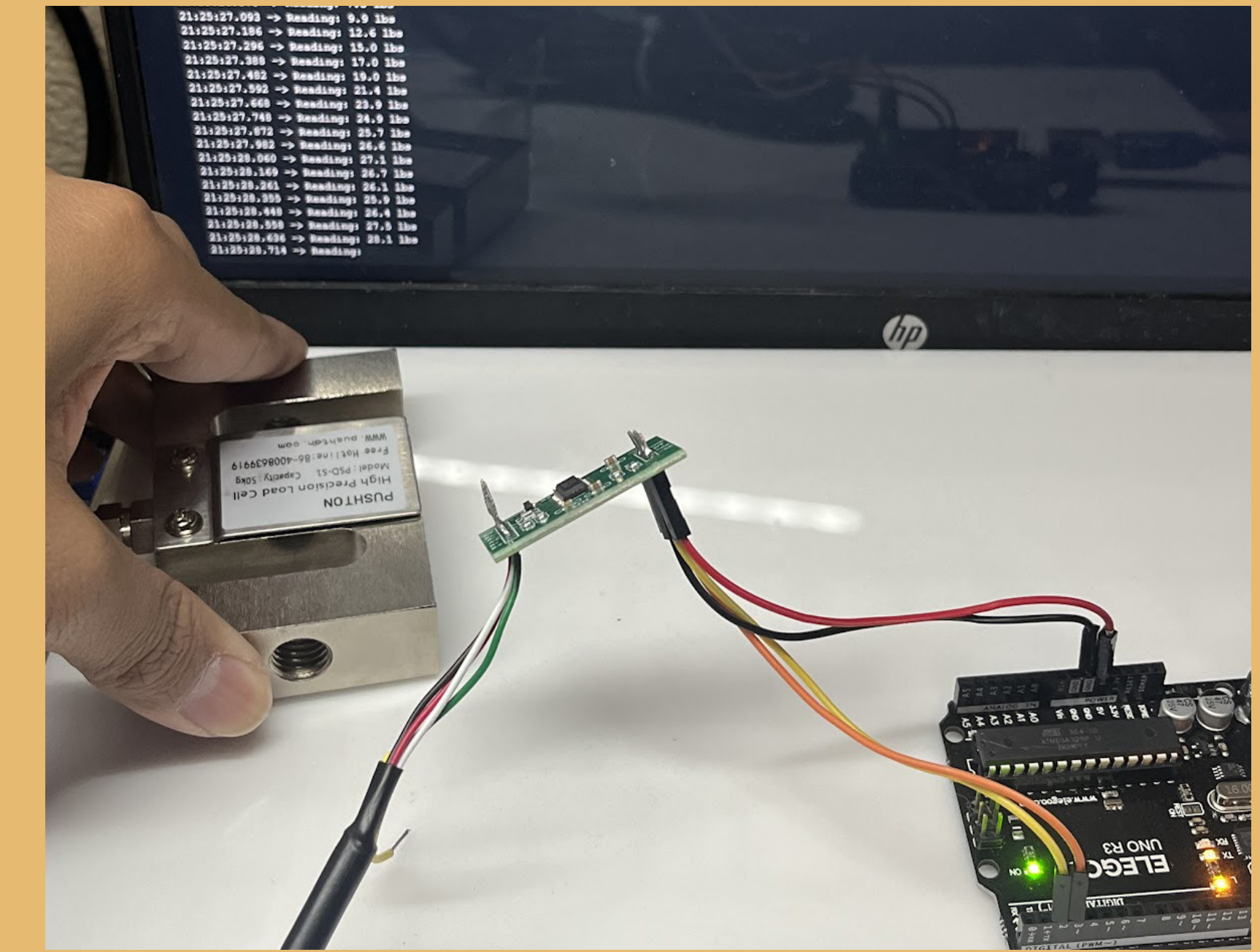

CAD Models

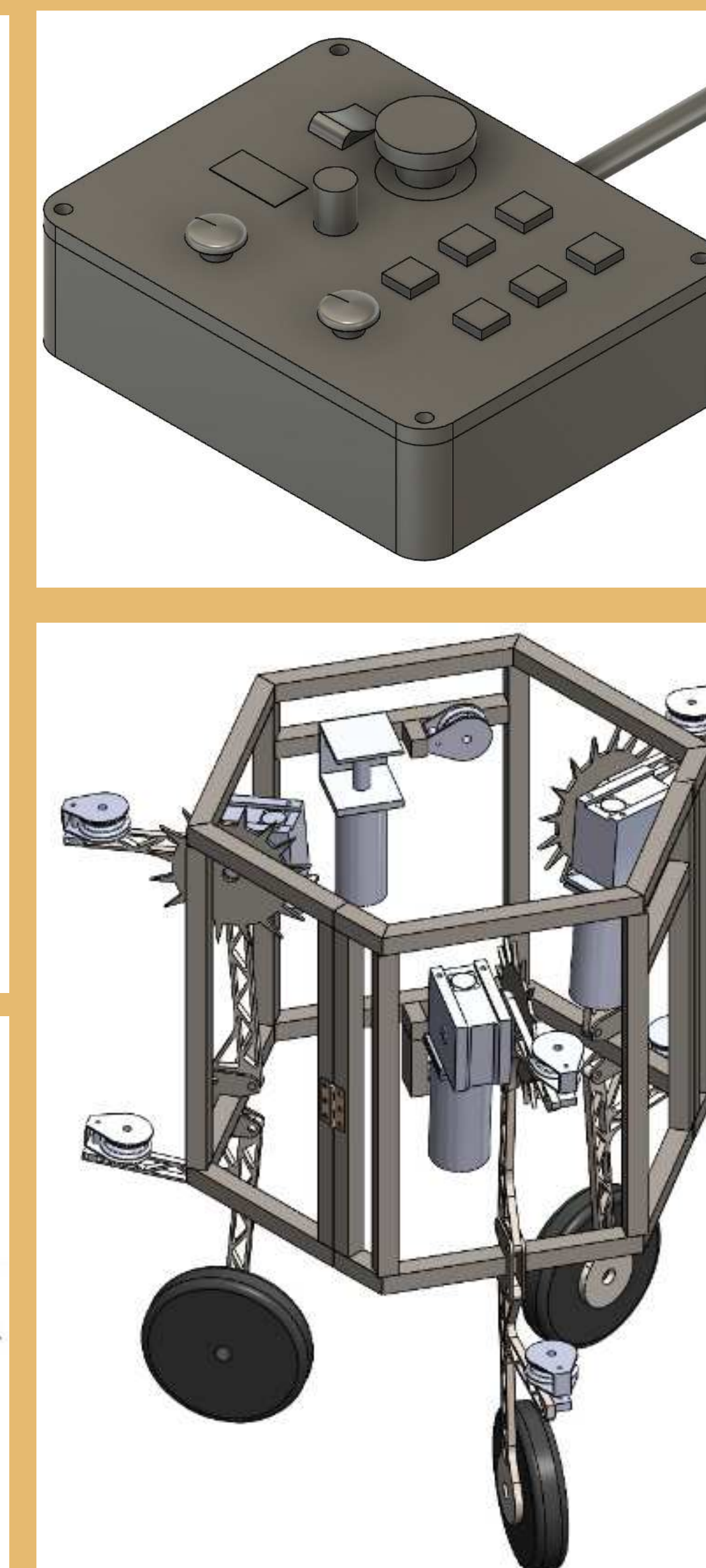
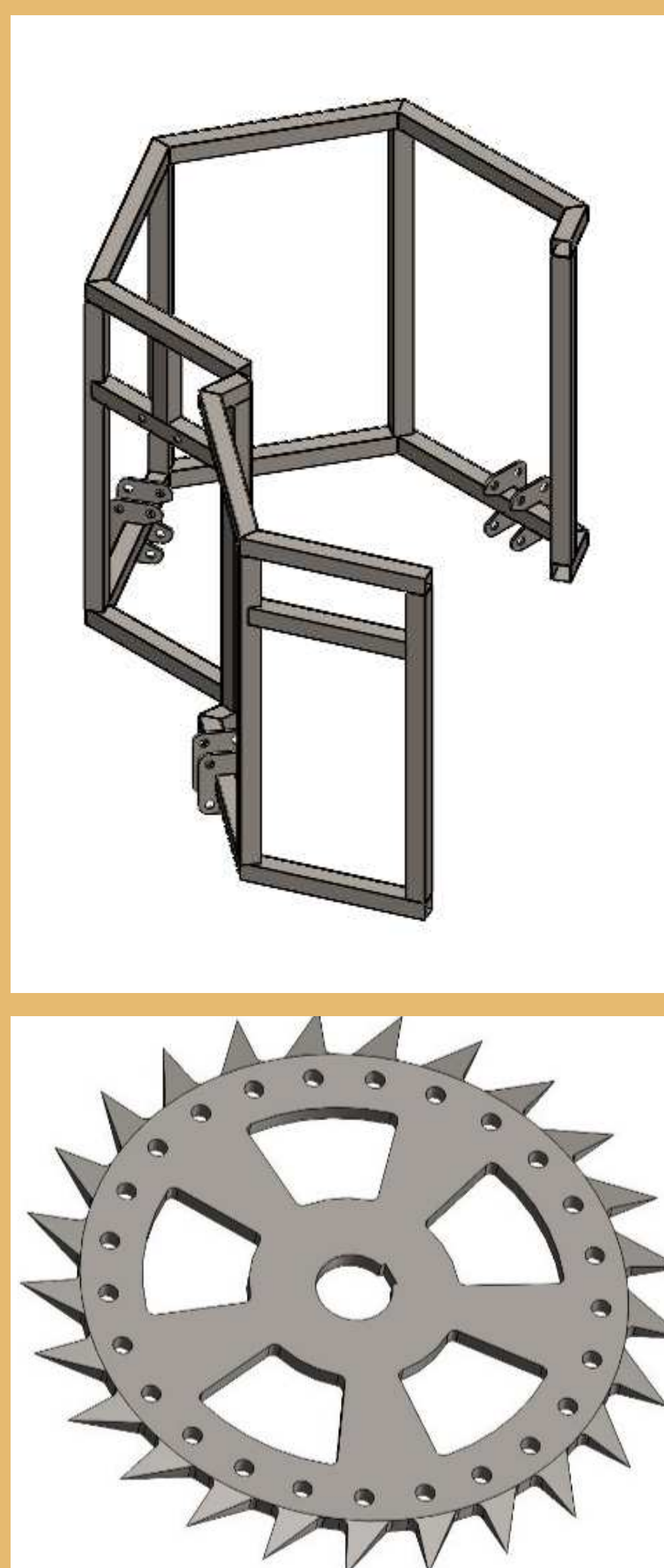
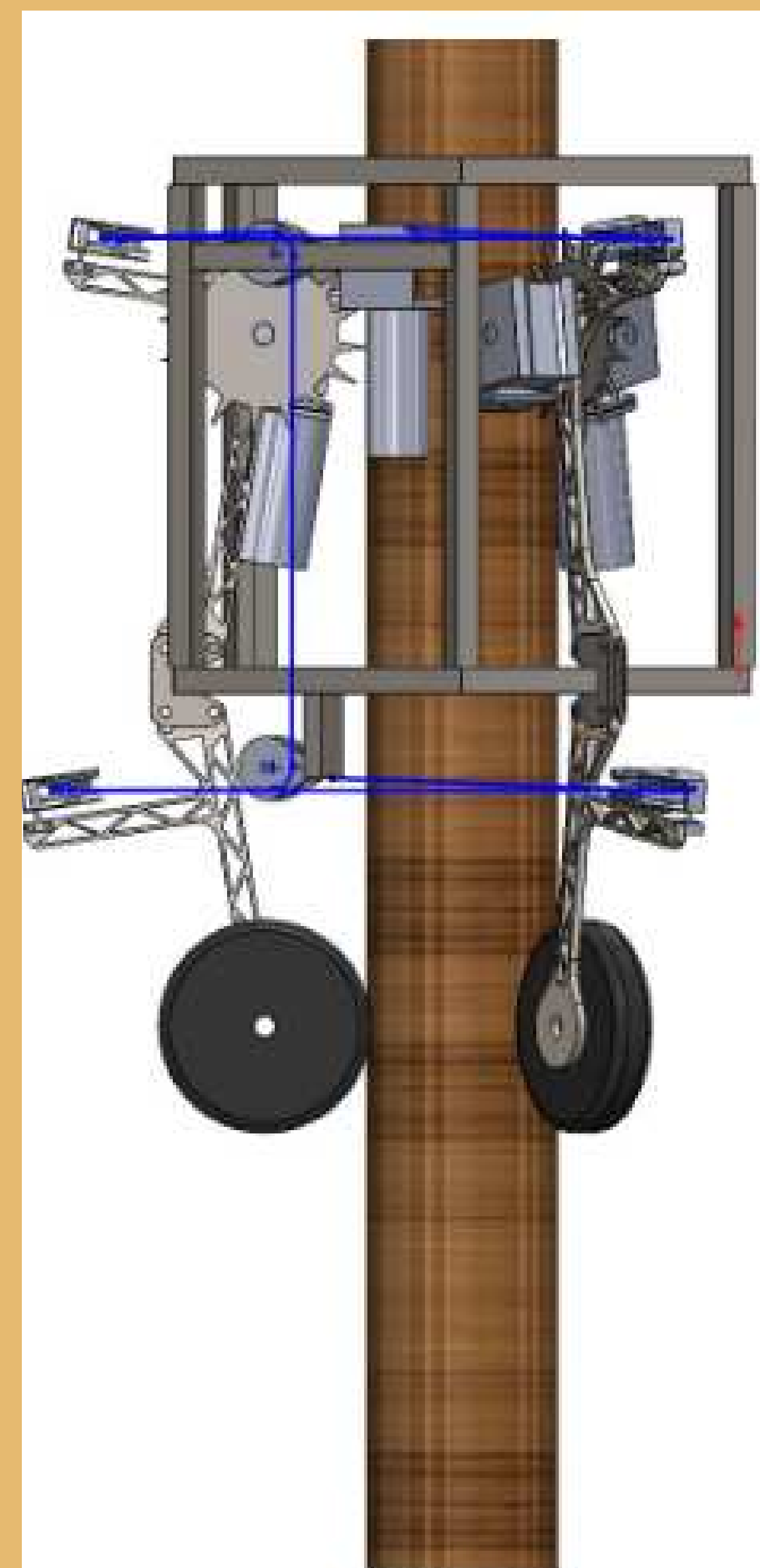

Acknowledgements

We would like to extend our gratitude to the following individuals for their continued support throughout this project.

- Dr. Scott Shaffar
- Dr. Barry Dorr
- Mr. Max Marek Winiarz
- Mr. Michael Lester
- Mrs. Louisa Burrus