



Team Members



Roland King



Mitchell Schick



Saray Basulto



Gurisher Rai

System CAD Model

PLATFORM

- 18" tall Platform has been constructed using Aluminum 6061 T6 to provide rigidity while reducing as much weight as possible.
- The bracket for assist pole attachment is present on both sides of the handle. This allows true 360 modularity around the EUV chamber
- The ergonomic handle allows for easy transport.



ASSIST POLE

- The armrest at the top provide the user support for safer reaching, a space for small components, a laptop surface or writing surface.
- The tool box attachment can store up to 25 lbs of tools or accessories for use with the system.
- Tool box and armrest swivel to better reach the user and can be attached at different heights.
- The pole weighs ~19lbs

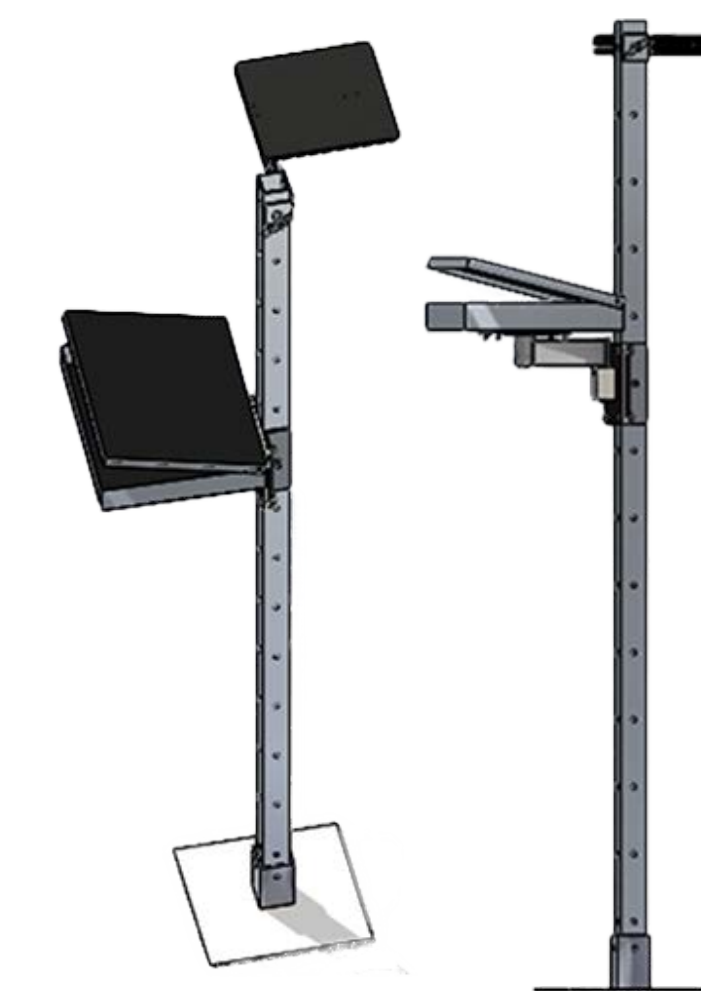

SAFETY STEP

- The step was modified to be independently stabled.
- Safety grip aids the user when stepping up to the platform and can be attached to either side of the ladder or both.
- Aluminum U channel provides rigidity and low weight, safety step weighs ~7lbs.

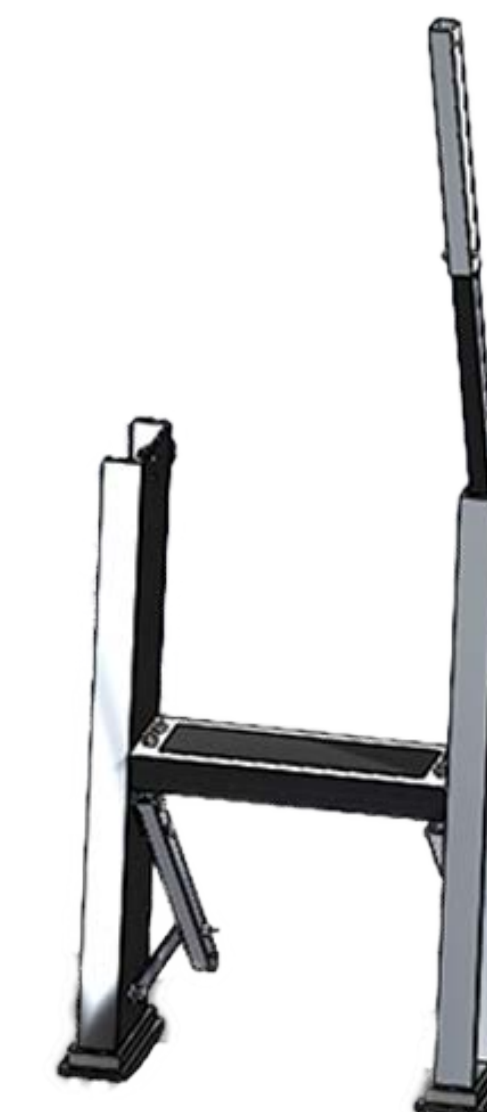

FOLDED PLATFORM

- System is designed to fold as flat as possible for storage.
- System can hang on a wall, lean against a wall or slide under the chamber.
- Platform weighs ~23lbs.

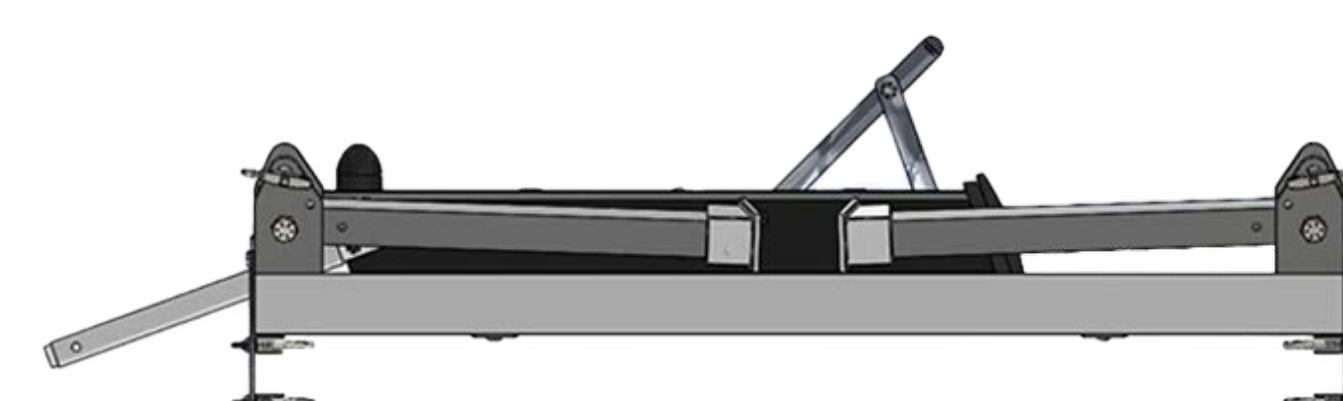

Fabrication



Problem Statement

The R&D maintenance and testing that is performed on the EUV test chamber is typically done at odd angles on the spherical chamber. The shape of the chamber and the limited space around it makes it difficult to access the chamber and perform mechanical and testing operations.

Design Analysis

SolidWorks FEA

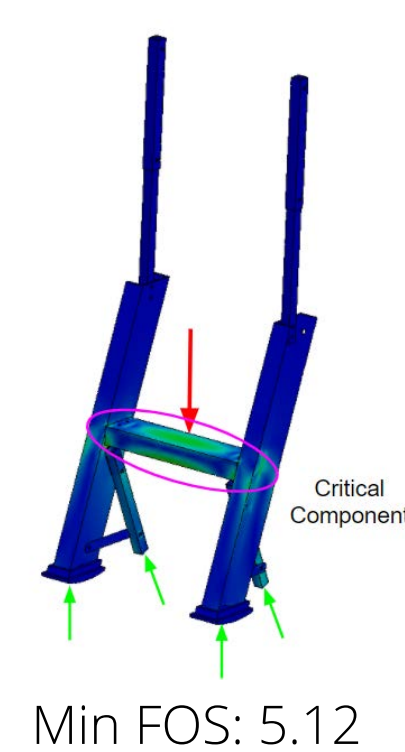
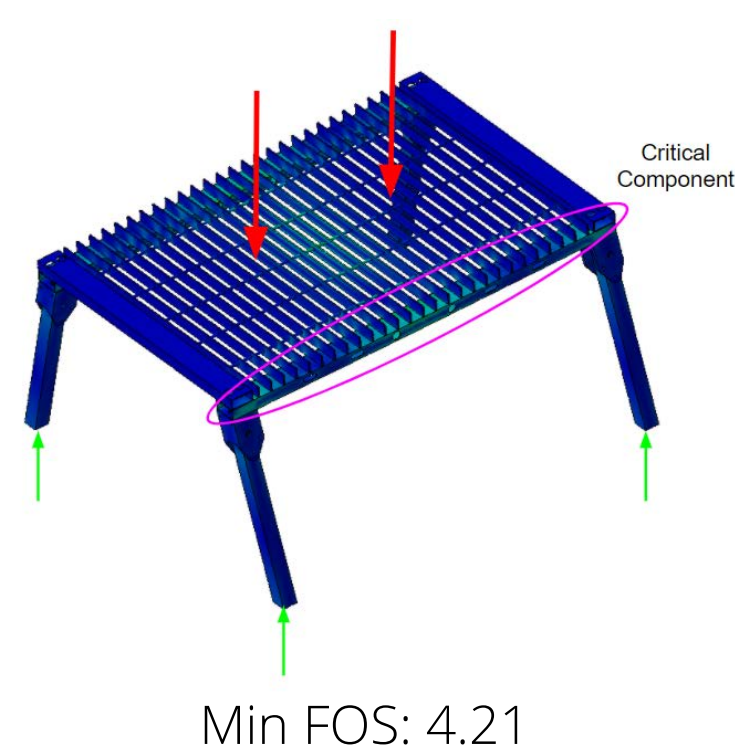

This design is a type I system having a weight capacity of 250lbf and must maintain a minimum factor of safety of 4.0. Using SolidWorks Simulation a finite element analysis was performed on each subsystem. Materials were chosen and geometries were designed to meet OSHA standards and ensure system will not fail under maximum loading conditions.

Final System

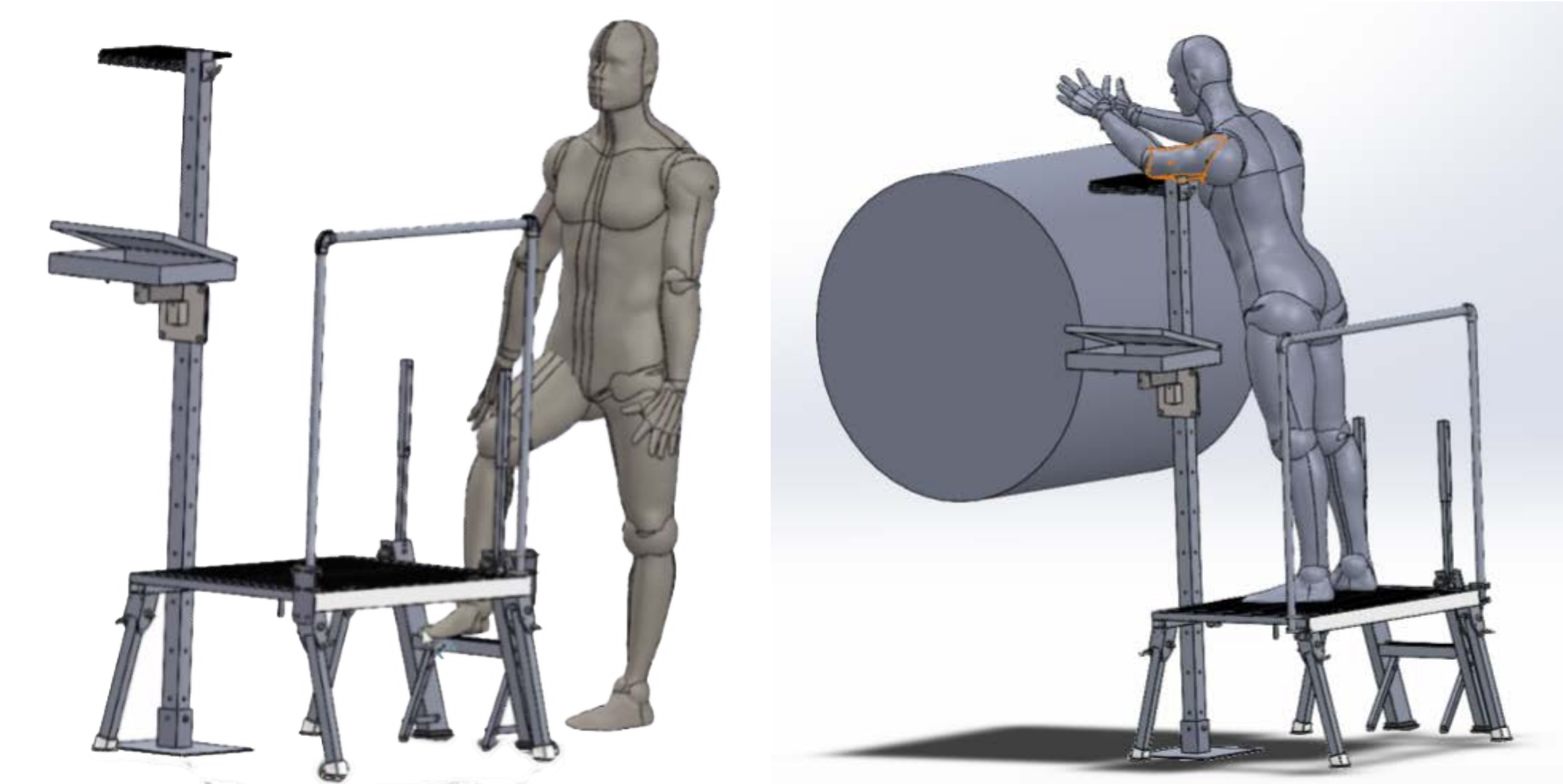

- The primary function of the system is to provide support for the technician by making work on the EUV chamber as efficient and safe as possible.
- Each component detaches from base to minimize weight.
- It takes approximately a minute to assemble the entire platform.