



Project Name: Pill Dispenser

Sponsor: Quality of Life Plus (QL+)

Created by: Team Pharmhouse

Advisors:
 Annemarie Orr, QL+
 COL Arthur Yeager MSOT, QL+
 Dr. Scott Shaffar, SDSU
 Barry Dorr, SDSU



Project Overview

Team Pharmhouse designed and manufactured a pill dispenser that is able to distribute a desired amount of medication pills to their respective days in both weekly and monthly pill organizers, including am and pm weekly containers. The dispenser also is able to be compatible with pills of a variety of shapes and sizes, as it is common for users to take multiple unique pills per day. The design will accommodate users with impairments such as arthritis, color-blindness, and various upper extremity issues. Simple, intuitive operations in conjunction with durability make this device the perfect solution. Lighter and smaller than similar products make transportation even easier.

Team Members



Chandler Meziere
Team Leader



Jeff Smith
Systems Engineer



Sean Myers
Manufacturing Engineer



Tony Nguyen
Software Engineer



David-Paul Sabado
Design Engineer



Jacob Martinez
Software Engineer



Naser Alfaresy
Procurement Engineer



Musaed Albaghdadi
Systems Engineer



Micah Spence
Quality Engineer



Jennifer Thai
Software Engineer

CAD Design

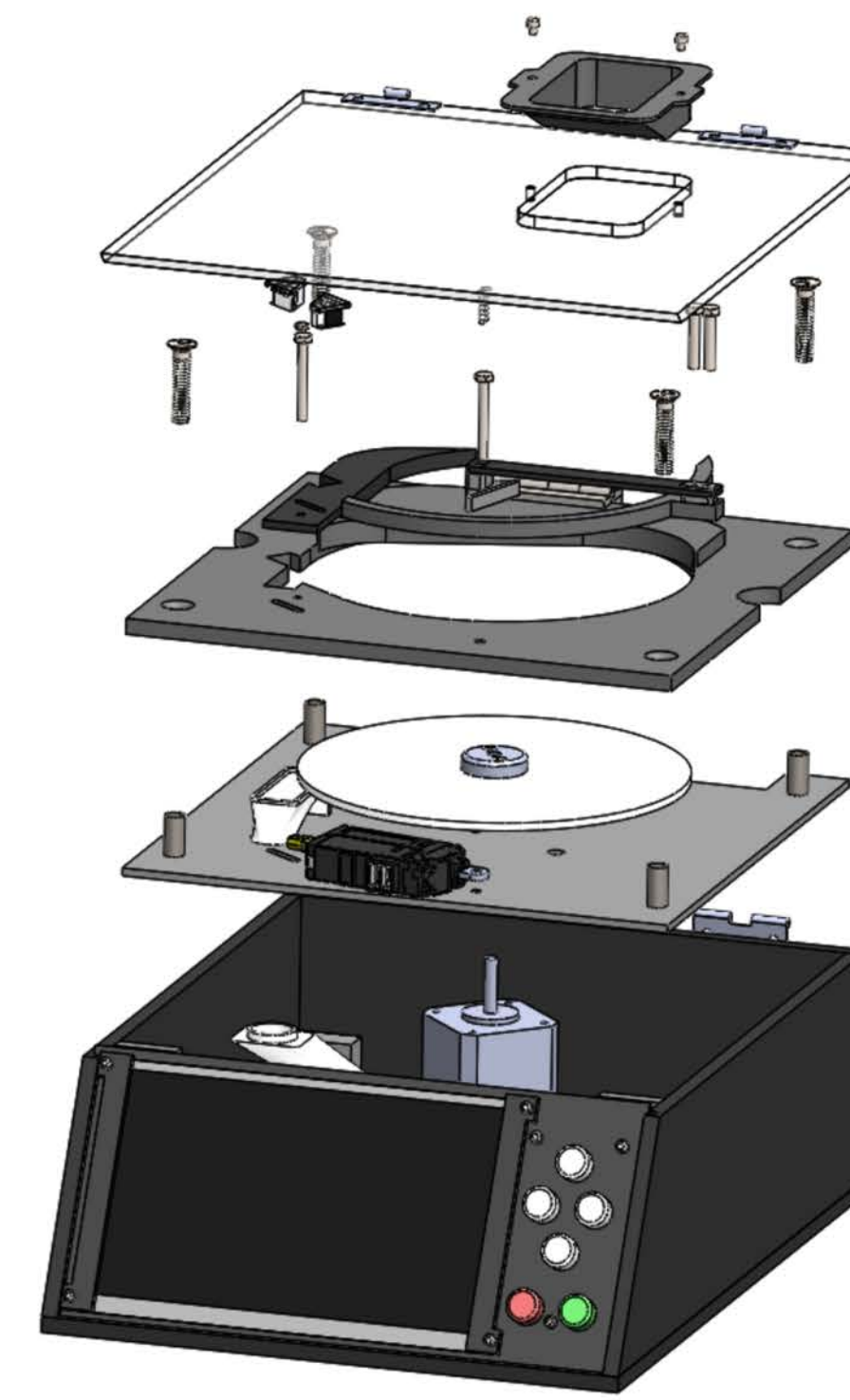

Counter Subsystem - Exploded View

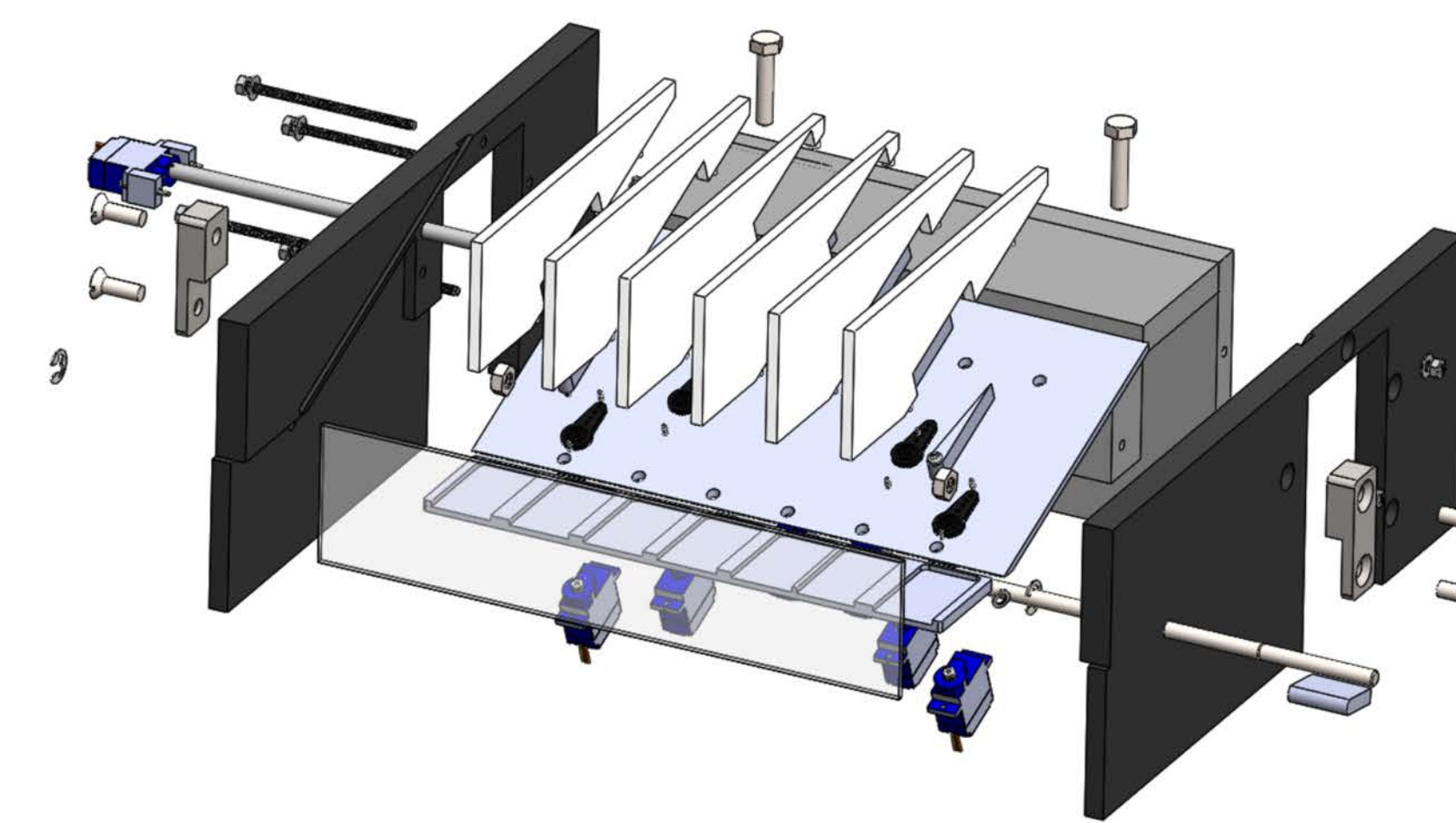

Separator Subsystem - Exploded View



Complete System - Collapsed View

Specifications

Size Envelope: 11.9" x 9.8" x 8.9"
 Power Required: 12V 60Hz AC
 Weight: 12.8 lbs.
 Transport Method: (2) 2" Nylon Straps

Main Components:
 - FDA Approved Food-Safe Materials
 - Arduino MEGA
 - Raspberry Pi 3B+
 - IR Break Beam Sensors

- Micro Precision Servo Actuator
 - Nema 17 Stepper Motor
 - SG90 Servo Motors
 - 7" LCD Screen
 - 12V Power Supply

Project Budget: \$5000
 Costs Spent: \$1214
 Excess Budget: \$3786

System Level Diagram

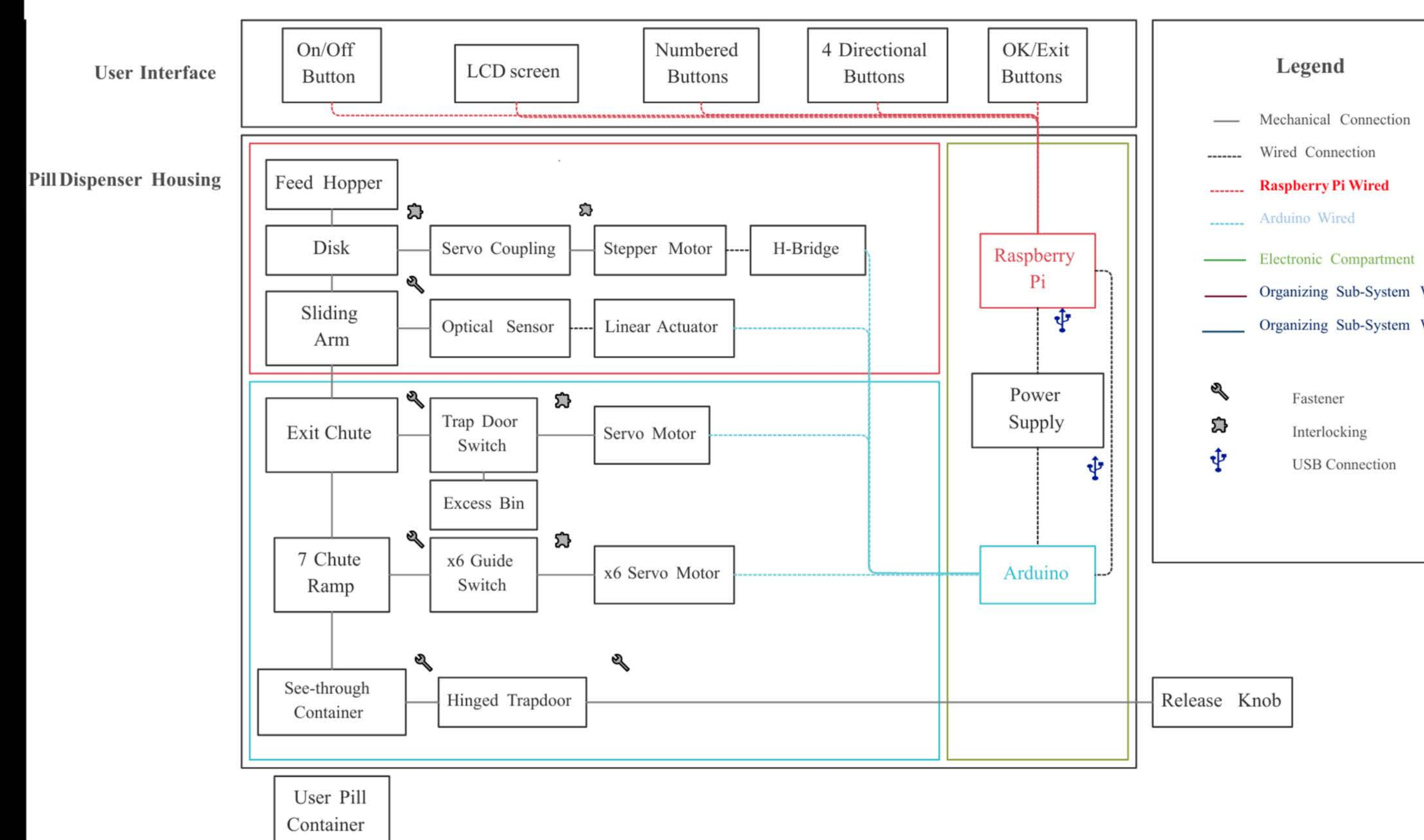

Electronic Connections Diagram

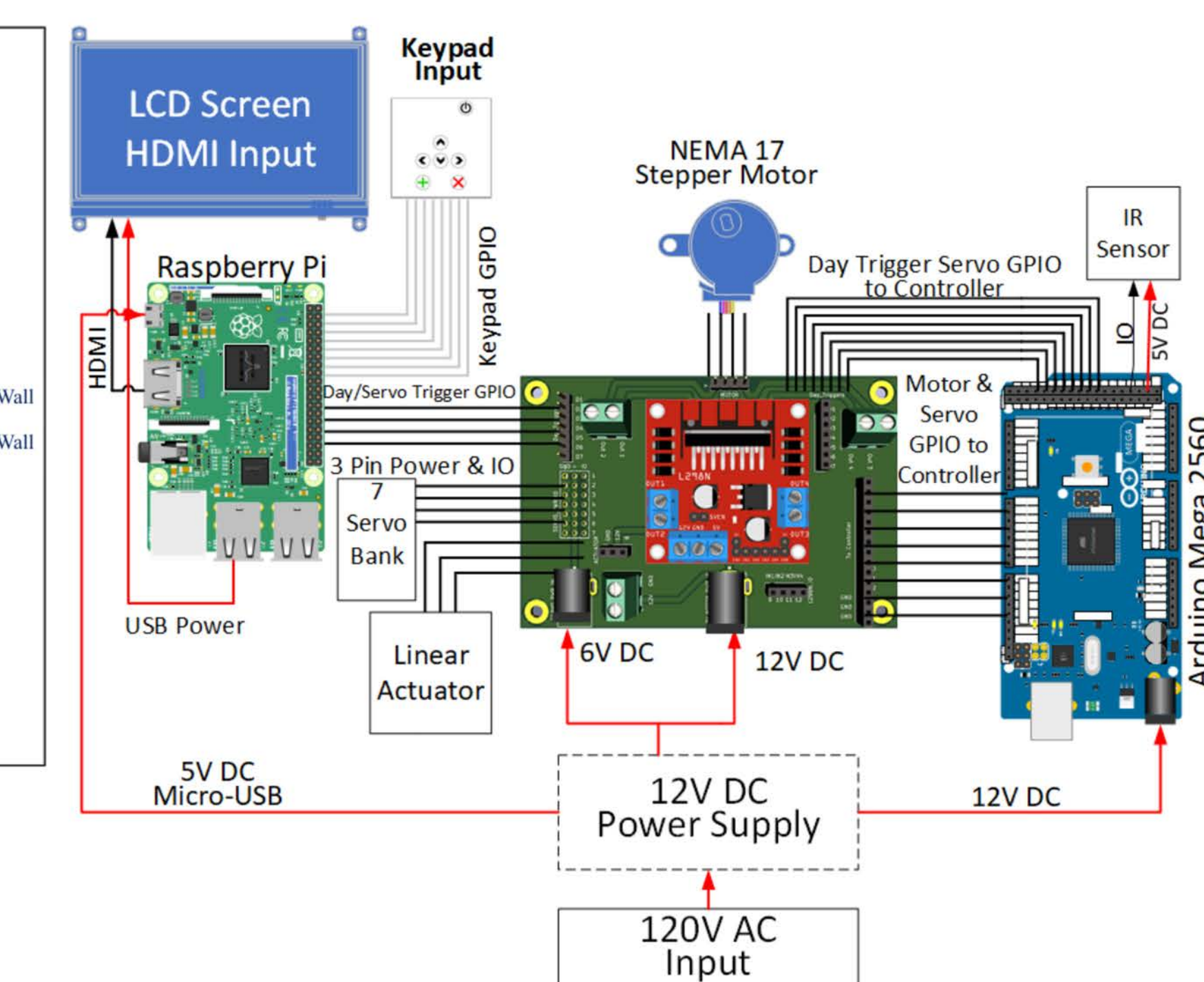

Manufactured Product

