



LED Laminar Pool Jet

SAN DIEGO STATE UNIVERSITY

Mission

To redesign and reduce the size of a Fluidra LED Laminar Pool Jet by incorporating a smaller LED light. The Laminar Pool Jet is to be designed for both compatibility of injection molding manufacturing, while also ensuring ease of assembly and installation

Deck Canister Assembly

The deck canister assembly is installed into the ground using the external rebar supports. The collar of the deck canister contains an internal lip that serves as a seat for the jet housing brackets. The deck canister lid sits flush onto the same internal lip and locks the rotation of the jet housing and lid together.

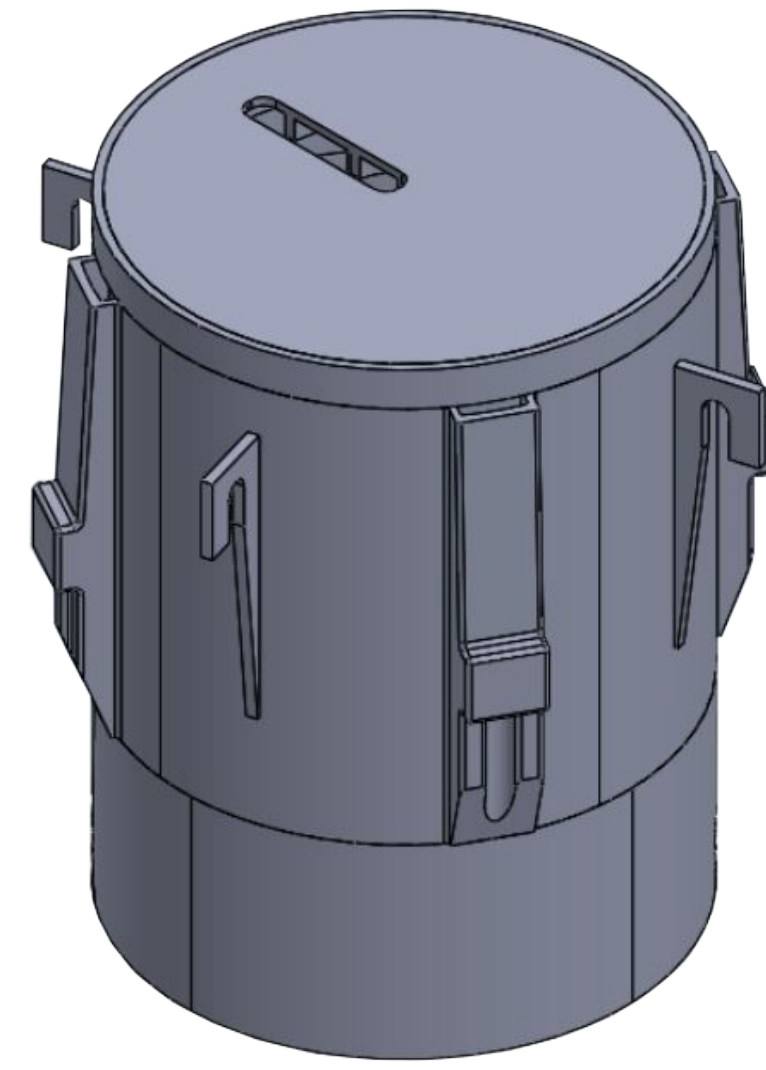

Jet Housing Assembly

The jet housing assembly consists of the water inlet port with a flow adjustment valve, two plastic integrated filters, four metal mesh filters, light intensity adjustor, lid, and brackets. The brackets are press-fit onto the hinges of the jet housing and are seated on the collar of the deck canister. The LED light engine is fastened onto the bottom of the jet housing with water tight seals and standard screws.

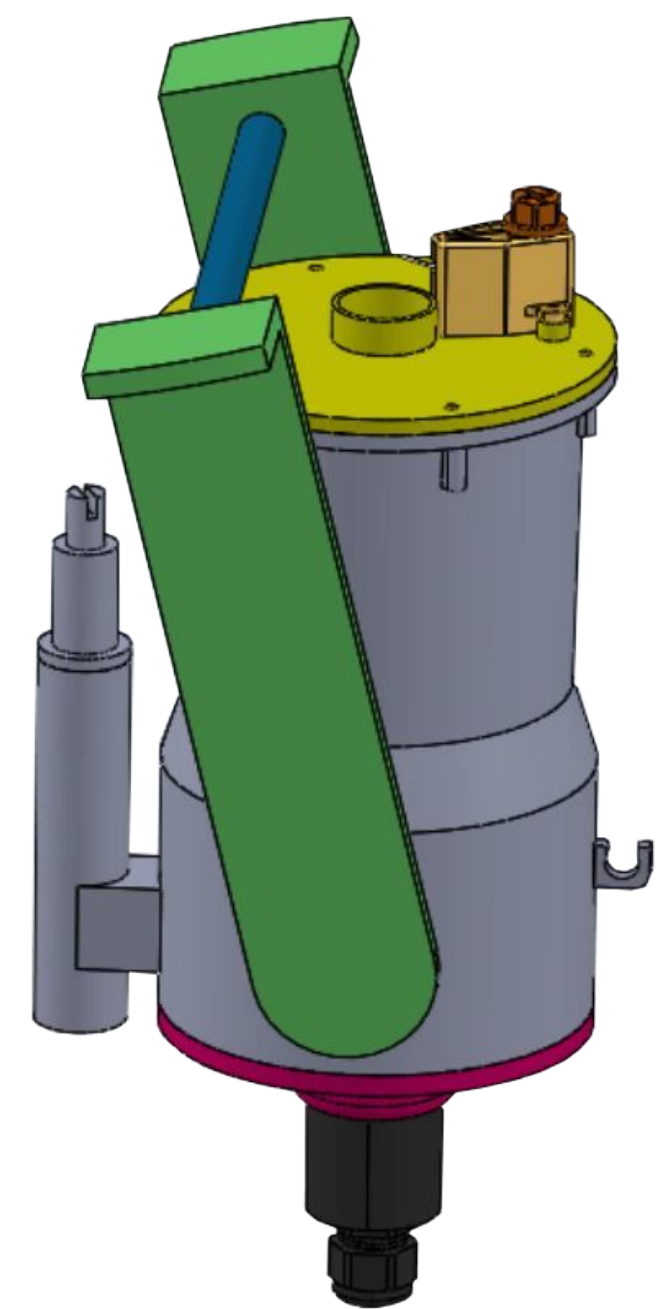

LED Light Engine Assembly

The light focuser (acrylic rod) is press-fit on top of the LED light and held together by the light cup (bottom) and focuser cup (top). The light cup slides on to the bottom of the LED light while the focuser cup slides over the light focuser. Both light and focuser cups are threaded together with waterproof sealing.

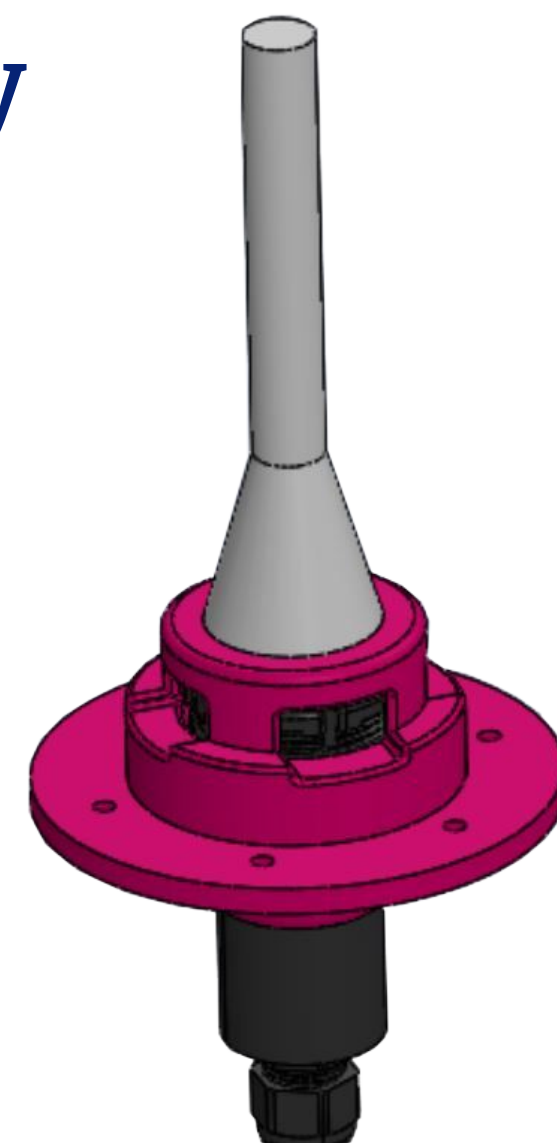

The Water Benders



Jack Chillemi, Tristan Morales, Charles Dudley, Jarod Ramirez

Key Requirements

- Design a laminar jet that provides a clear arcing stream of water
- Size reduction of all components of original Fluidra water jet design
- Laminar jet must include specified LED light platform
- LED light must be able to travel through the stream of water
- Intensity of the light in the laminar jet must be adjustable
- Laminar jet arc length must be adjustable
- The angle of the jet stream must be adjustable
- Product material must be NSF compliant
- Budget: \$4000 by our sponsor Fluidra

Analysis

- Pressure Vessel Simulation-Demonstrates that the Jet Housing can successfully withstand 2.5 times more pressure(35 PSI) than its working pressure (14 PSI)
- Fluid Flow Simulation - Streamlines demonstrate how the flow becomes laminar through a series of filters, as well as the pressure distribution throughout the Jet housing

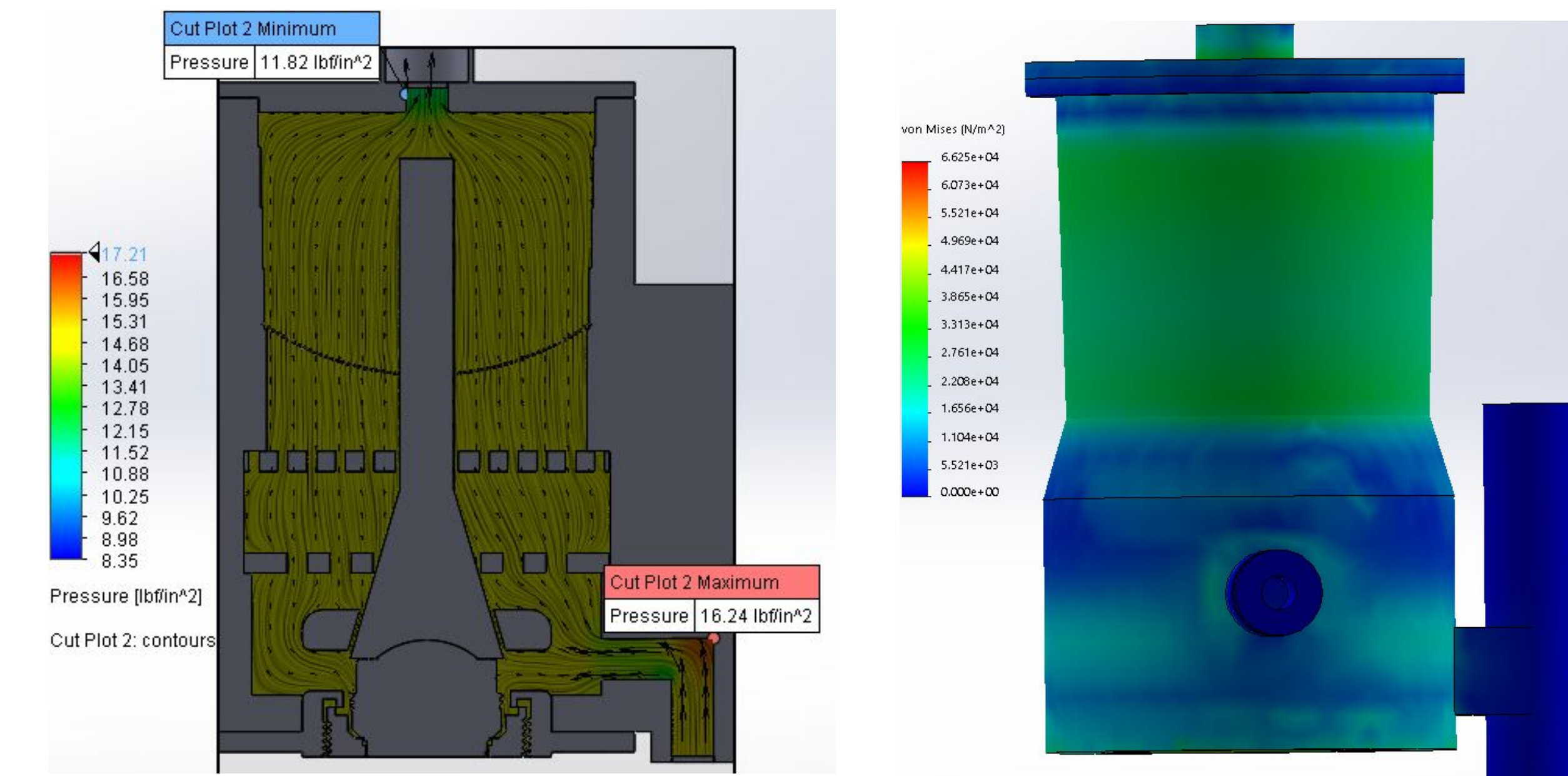

Testing

- Jet Housing volume reduction of over 34%
- Deck Canister volume reduction of 26%
- Laminar Jet length & height requirement met

